



This document contains information proprietary to  
**ADVANCED GROUND SYSTEMS ENGINEERING LLC**  
and shall not be reproduced, transferred to other documents, disclosed to others, or used for  
any purpose other than that for which it is furnished without the prior written permission of  
Advanced Ground Systems Engineering LLC.

---

---

# **AGSE-E259-G03**

## **(PWA211330 REV B)**

---

---

### **Transportation Stand**

**For Pratt & Whitney  
PW1130G-JM Engine & PW1400G-JM Engine**

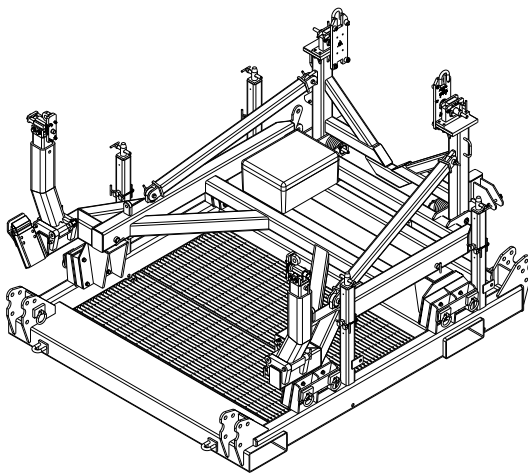

ORIGINAL MANUAL DATED..... 7/18/2023

LATEST MANUAL REVISION LEVEL..... 7/18/2023 (REV NC)

**ADVANCED GROUND SYSTEMS ENGINEERING LLC**

10805 Painter Ave., Santa Fe Springs, CA, 90670 • PHONE: 562-906-9300 • FAX: 562-906-9308 • E-MAIL: [agse@agsecorp.com](mailto:agse@agsecorp.com)

---

---

# NOTICE

---

---

## **1. Alteration, Modification, Reengineering, or Reproduction of Equipment**

The alteration, modification, reengineering, or reproduction of AGSE equipment and/or parts is not permitted without prior written authorization from AGSE.

These modifications include but are not limited to:

- Structural changes to AGSE-supplied parts
- Substitution of AGSE-supplied parts, including hardware, with an alternate source or supplier
- Reverse engineering of AGSE equipment and parts.

Requests for modifications should be submitted to AGSE for review – please send modification requests to [\*\*support@agsecorp.com\*\*](mailto:support@agsecorp.com).

Once reviewed by our Engineering team, a Customer Support Letter (Subject: No Technical Objection) will be issued for any approved modifications.

<b>NOTE</b>
-------------

**Modifications executed without prior authorization by AGSE may result in a non-compliant product that is unsafe for operation.**

**Unauthorized modifications void AGSE's and the OEM's (Engine and/ or Airframer) approval and authority to use the product for its intended application.**

# INDEX

SECTION	DESCRIPTION	PAGE(S)
1.0	Revisions . . . . .	1.0
2.0	Illustrations . . . . .	2.0
3.0	Specification . . . . .	3.0
3.0	3.1 General . . . . .	3.0
3.0	3.2 Design . . . . .	3.0
3.0	3.3 Mobility . . . . .	3.0
3.0	3.4 Fabrication and Finish . . . . .	3.0
3.0	3.5 Characteristics . . . . .	3.1
4.0	Maintenance and Inspection . . . . .	4.0
4.0	4.1 General . . . . .	4.0
4.0	4.2 Cleaning and Painting . . . . .	4.0
4.0	4.3 Scheduled Service . . . . .	4.0
4.0	4.4 Scheduled Inspection . . . . .	4.0
4.0	4.5 General Maintenance Schedule . . . . .	4.2
5.0	Operation . . . . .	5.0
5.0	5.1 Engine Installation into Stand . . . . .	5.0
5.0	5.2 Stowing the Cradle for Stacking and Transport . . . . .	5.6
5.0	5.2.1 Stowing Cradle . . . . .	5.6
5.0	5.2.2 Stacking . . . . .	5.9
5.0	5.3 Truck Tie-Down . . . . .	5.11
5.0	5.3.1 Air Shipment . . . . .	5.11
5.0	5.3.2 Truck Shipment . . . . .	5.11
6.0	Safety . . . . .	6.0
6.0	6.1 Stress . . . . .	6.0
6.0	6.2 General . . . . .	6.0
6.0	6.3 Prevention . . . . .	6.0
6.0	6.4 Risk Assessment . . . . .	6.0
6.0	6.4.1 Limits Machinery . . . . .	6.0
6.0	6.4.2 Risk Assessment and Residual Risk . . . . .	6.1
7.0	Warranty . . . . .	7.0
7.0	7.1 Statement of Warranty . . . . .	7.0
8.0	Parts Breakdown . . . . .	8.0
8.0	8.1 General . . . . .	8.0
8.0	8.2 Illustrated Parts Breakdown . . . . .	8.0
8.0	IPB Figure 1- AGSE-E259-G03 Engine Transport Stand Assembly . . . . .	8.1
8.0	IPB Figure 2 - AGSE-E25901-S01 Base Assembly . . . . .	8.3
8.0	IPB Figure 3 - AGSE-E25902-S03 Cradle Assembly . . . . .	8.5

---

---

# INDEX (Continued)

---

---

SECTION	DESCRIPTION	PAGE(S)
8.0	IPB Figure 4 - AGSE-E25948-S01 Fixed AFT Mount Assy - LH . . . .	8.9
8.0	IPB Figure 5 - AGSE-E25948-S02 Adj AFT Mount Assy - RH. . . .	8.11
8.0	IPB Figure 6 - AGSE-E25960-S01 Fixed FWD Mount Assy - LH . .	8.13
8.0	IPB Figure 7 - AGSE-E25960-S02 Adj FWD Mount Assy - RH . . . .	8.15
9.0	Stencils, Decals, and Placards . . . . .	9.0
9.0	9.1 General . . . . .	9.0
9.0	9.2 Stencils and Placards . . . . .	9.0
10.0	Recommended Spare Parts List . . . . .	10.0
10.0	10.1 Critical Items . . . . .	10.0

---

---

# 1.0 – Revisions

---

---

The following is an itemized record of all changes from previous revision.

<b>PAGE</b>	<b>REV</b>	<b>DESCRIPTION OF CHANGE</b>	<b>DATE</b>
		NEW	

---

---

## 2.0 – Illustrations

---

---

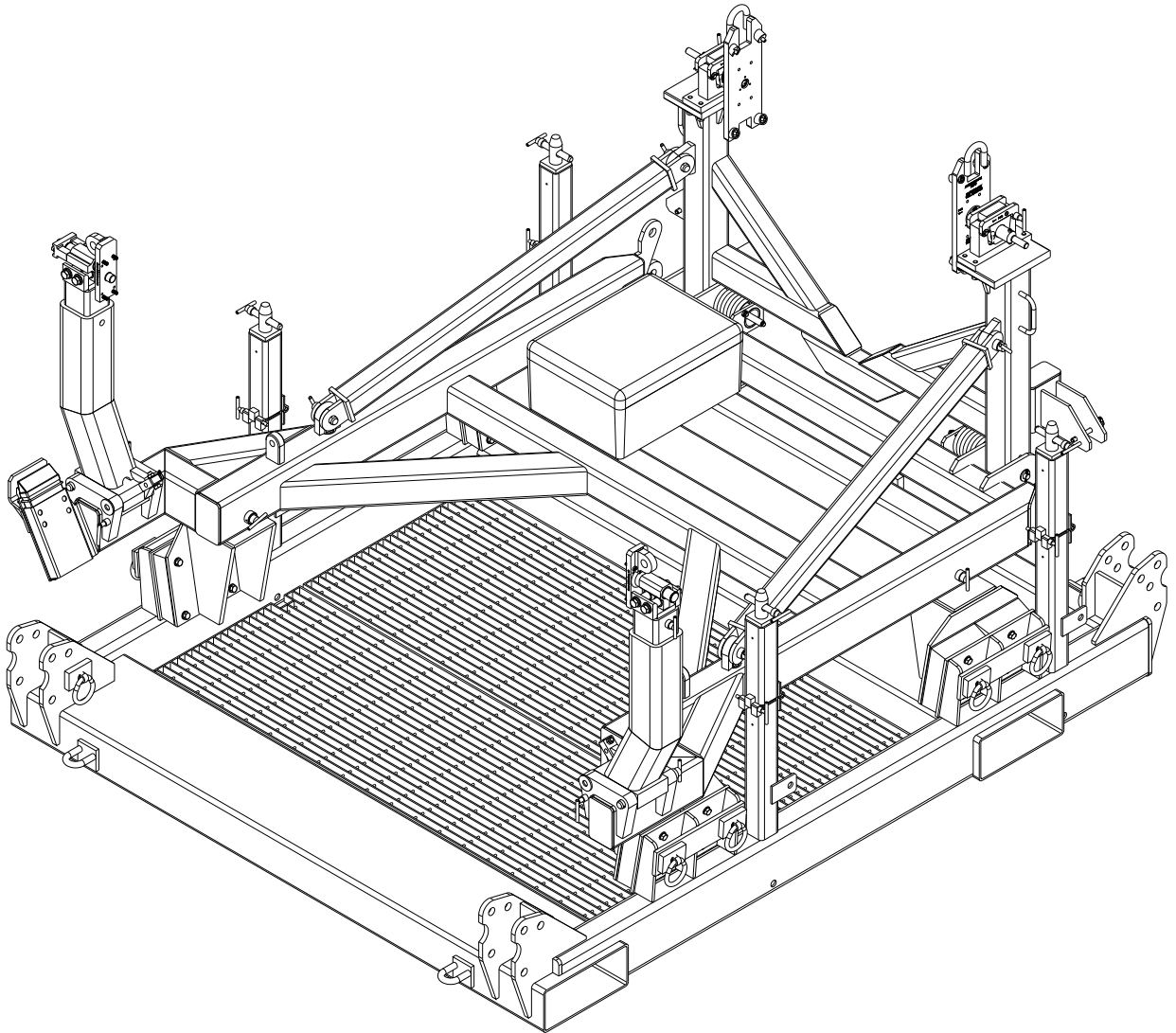

*Figure 2.0-1 AGSE-E259-G03 (PWA211330 REV B) Engine Transport Stand*

---

---

## 2.0 – Illustrations (Continued)

---

---

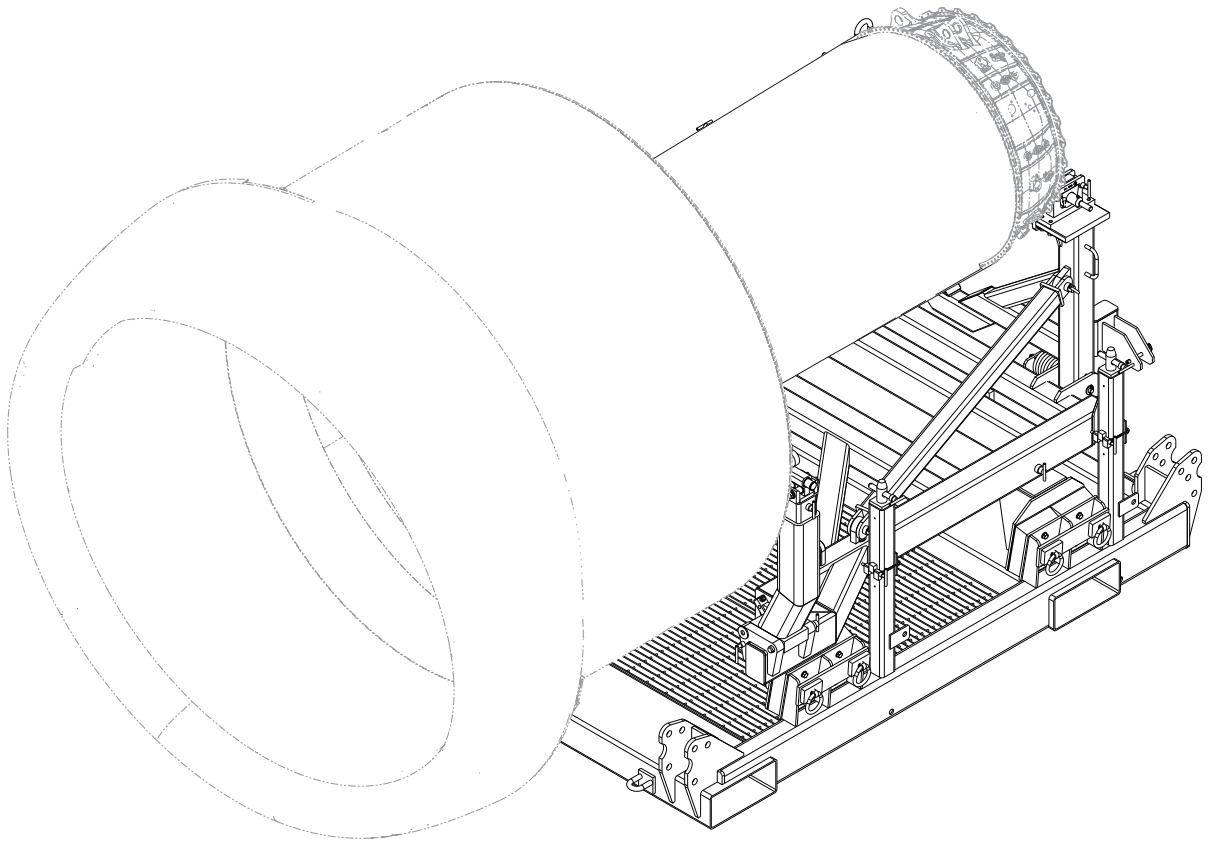

*Figure 2.0-2 AGSE-E259-G03 (PWA211330 REV B) Engine Transport Stand with PW1130G Engine*

---

---

## 2.0 – Illustrations (Continued)

---

---

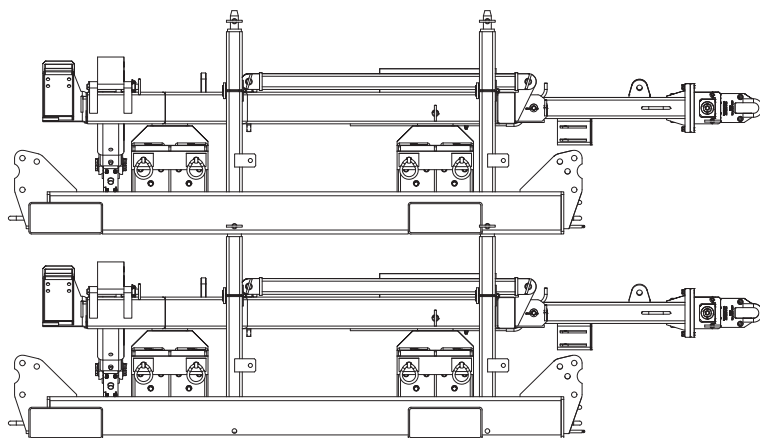
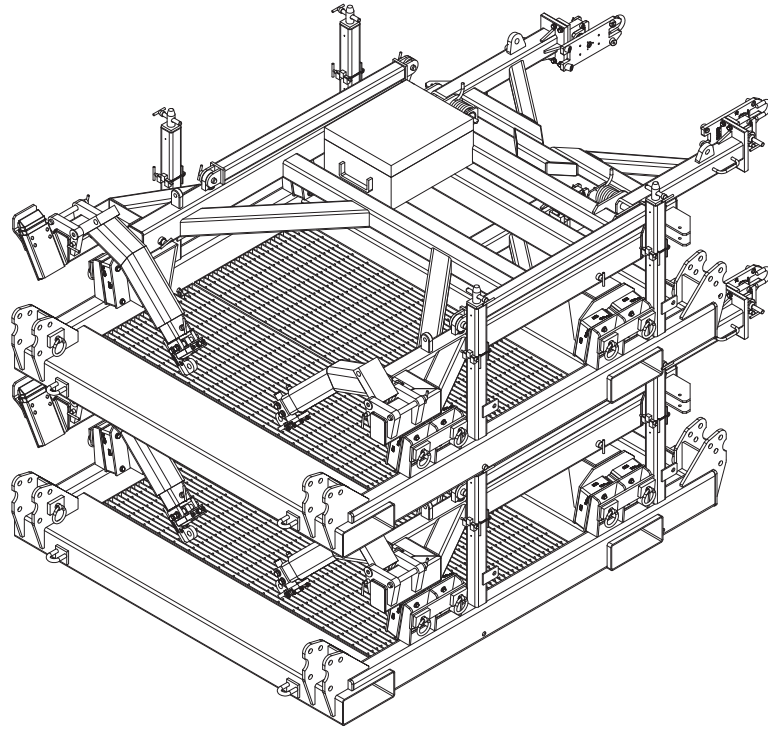

*Figure 2.0-3 AGSE-E259-G03 (PWA211330 REV B) Engine Transport Stands Double Stacked*



---

---

## 2.0 – Illustrations (Continued)

---

---

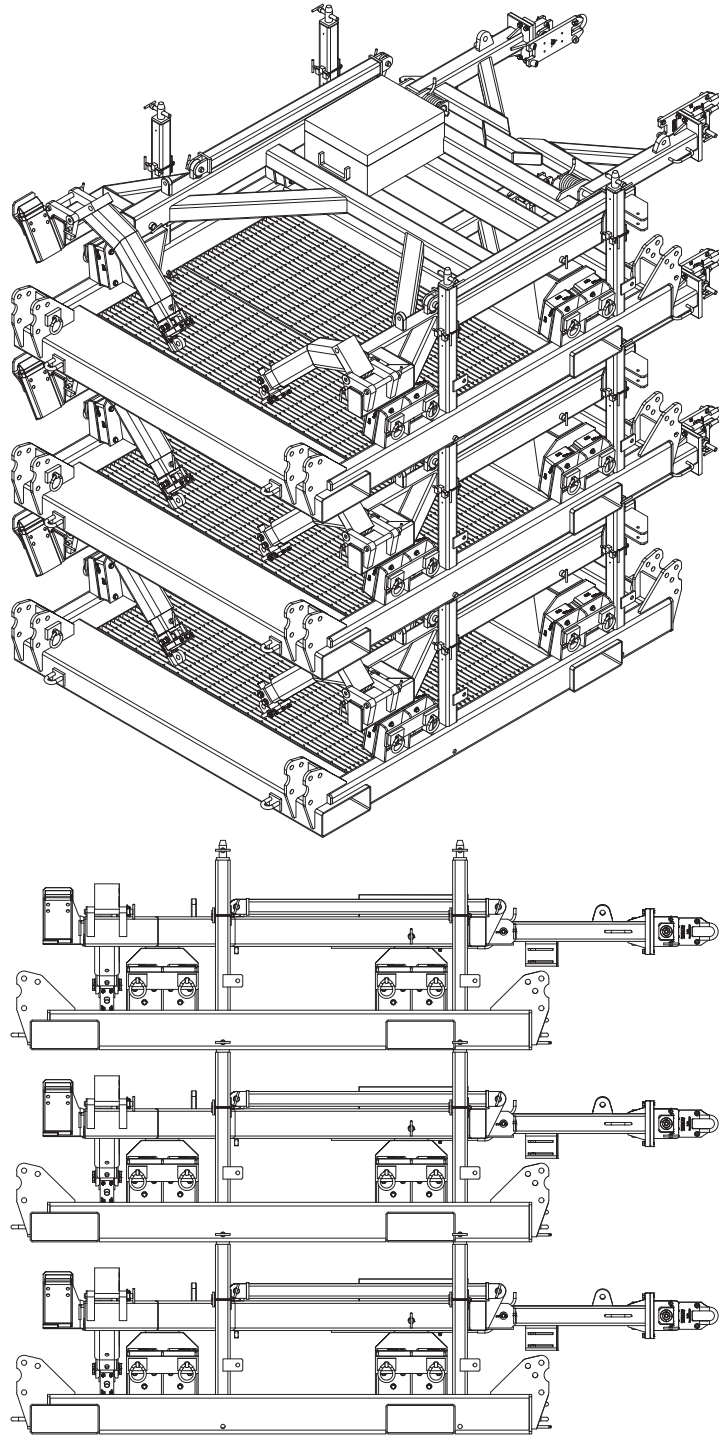

*Figure 2.0-4 AGSE-E259-G03 (PWA211330 REV B) Engine Transport Stands Triple Stacked*

---

---

## 3.0 – Specification

---

---

### 3.1 General

The AGSE-E259-G03 (PWA211330 REV B) engine transport stand is designed to transport and/or store the Pratt & Whitney PW1130G-JM and PW1400G-JM production engines, or transport the QEC engines, minus the inlet. The stand can also be used to store either the production engines or full QEC engines, including the inlet. The stand should NOT be used to ship a full QEC engine with the inlet installed. The stand is designed and tested per Pratt & Whitney's Ground Support Equipment Specification GSE 3027, "Full Engine Production Transport Stand for the PW1130G Engine." The stand is capable of being shipped on the main deck of B747 Freighter Aircraft. The engine pins securely into place quickly and easily. A component storage box is secured to the base for all mounts and adapters. The stand is fork liftable from either side.

### 3.2 Design

The AGSE-E25902-S03 cradle consists of a welded steel frame with removable engine ground handling mounts compatible with the PW1130G-JM and PW1400G-JM engines. Tubular arms support the engine handling mounts.

The AGSE-E25901-S01 Base consists of a welded steel frame with integral shock mounts to dampen ground handling loads and vibrations.

### 3.3 Mobility

There are numerous tie down rings located on the base to secure the stand to a truck trailer for truck shipment.

<b>CAUTION</b>
----------------

**The cradle must never be tied directly down to the truck bed. Truck shipment using a truck trailer equipped with an "air-ride" type suspension system is mandatory.**

### 3.4 Fabrication and Finish

The stand is fabricated from structural steel shapes conforming to ASTM A500, A513, and A36 materials. All bolted connections use A325 structural bolts or SAE Grade 5 commercial hardware. Unit is primed and painted with high-grade, Skydrol resistant enamel, with color optional. Pins and miscellaneous hardware are manufactured from corrosion resistant materials, or plated as required.

### 3.5 Characteristics

<b>Length (In.)</b>	111-3/4
<b>Width - Base Only (In.)</b>	88
<b>Width - Base and Cradle (In.)</b>	102-1/2
<b>Height (In.)</b>	69-3/4
<b>Engine CL (In.)</b>	N/A
<b>Cradle Weight (Lbs.)</b>	1,800
<b>Base Weight (Lbs)</b>	1,743
<b>Total Weight (Lbs.)</b>	3,543
<b>Stacked-Two Height</b>	72-1/2
<b>Stacked-Three Height</b>	111-3/4
<b>Stacked-Two Weight</b>	7,086
<b>Stacked-Three Weight</b>	10,629

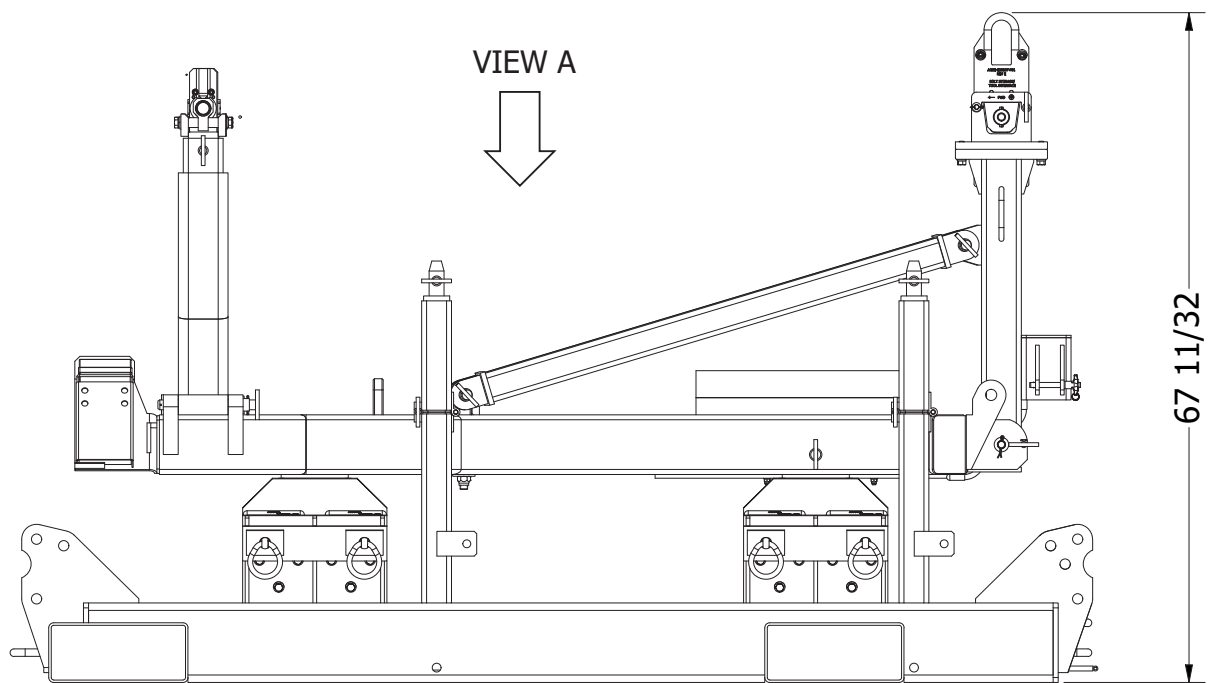

*Figure 3.5-1*

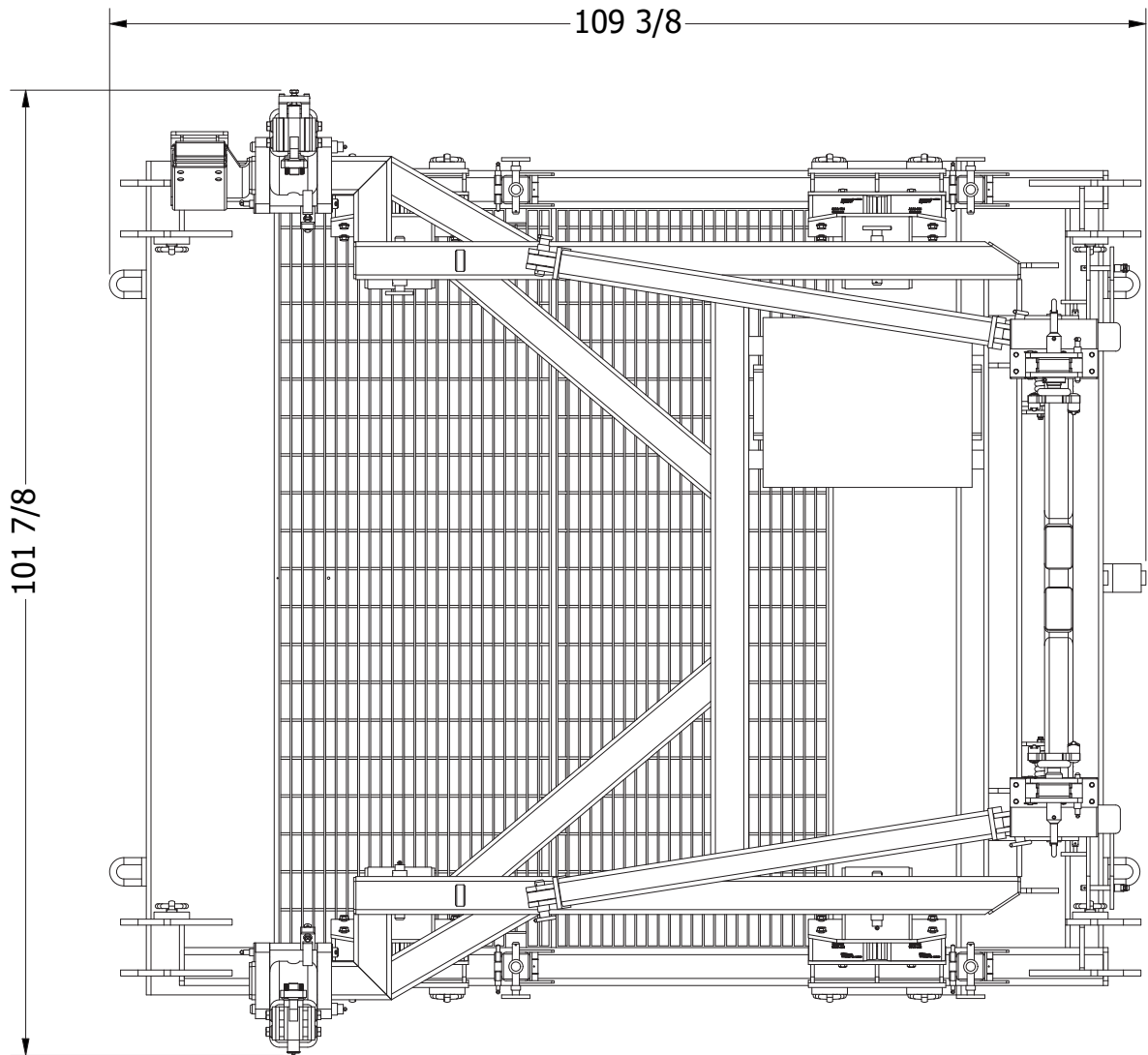

*Figure 3.5-2*

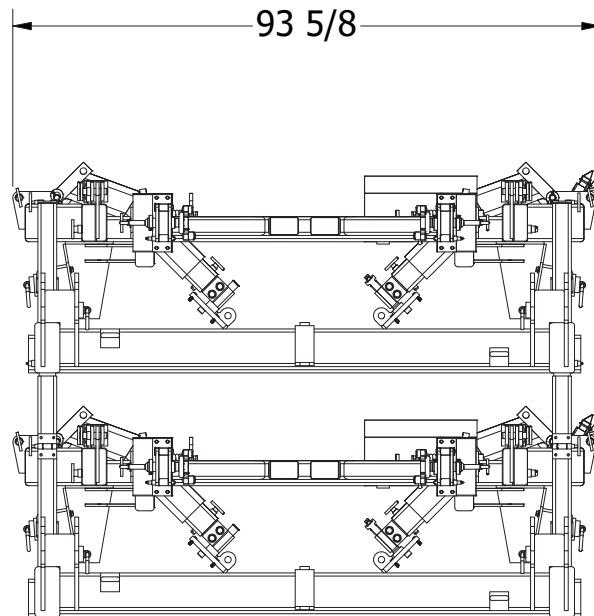
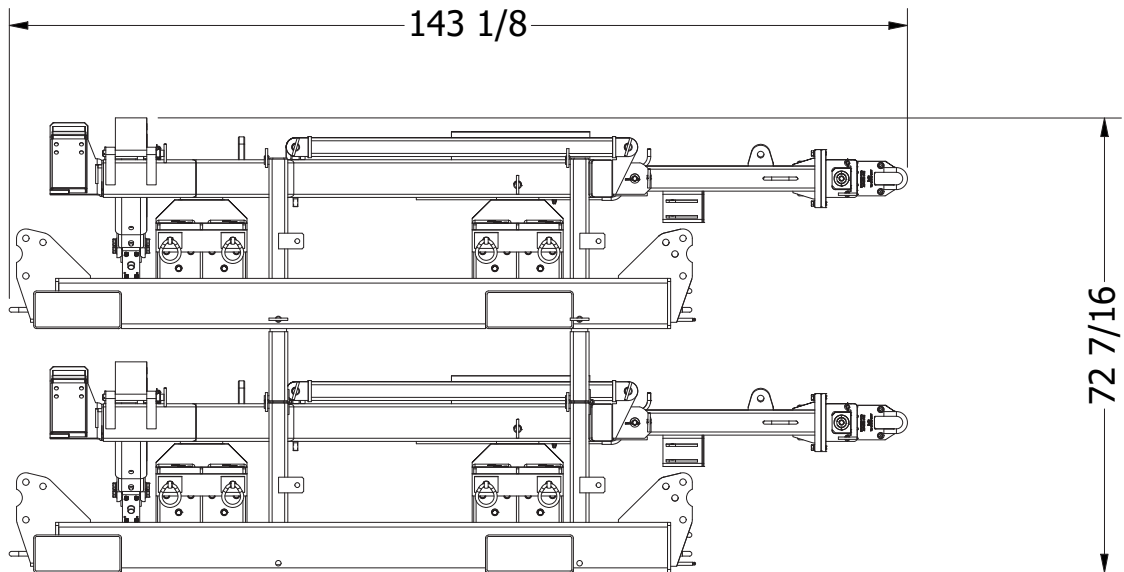

Figure 3.5-3

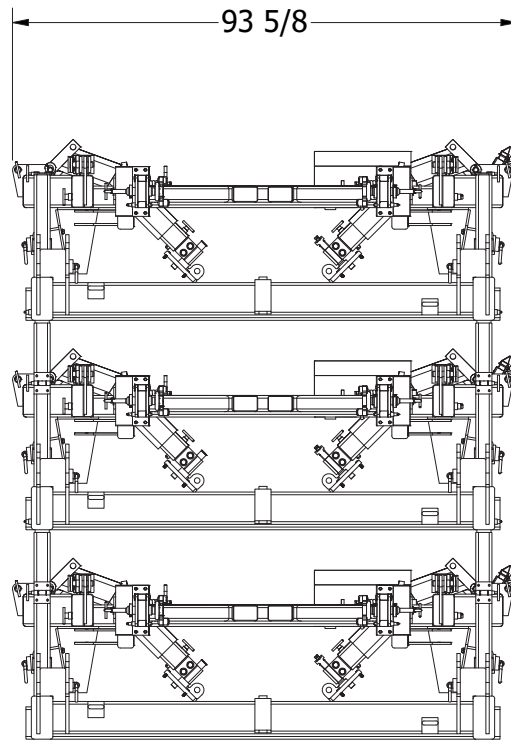
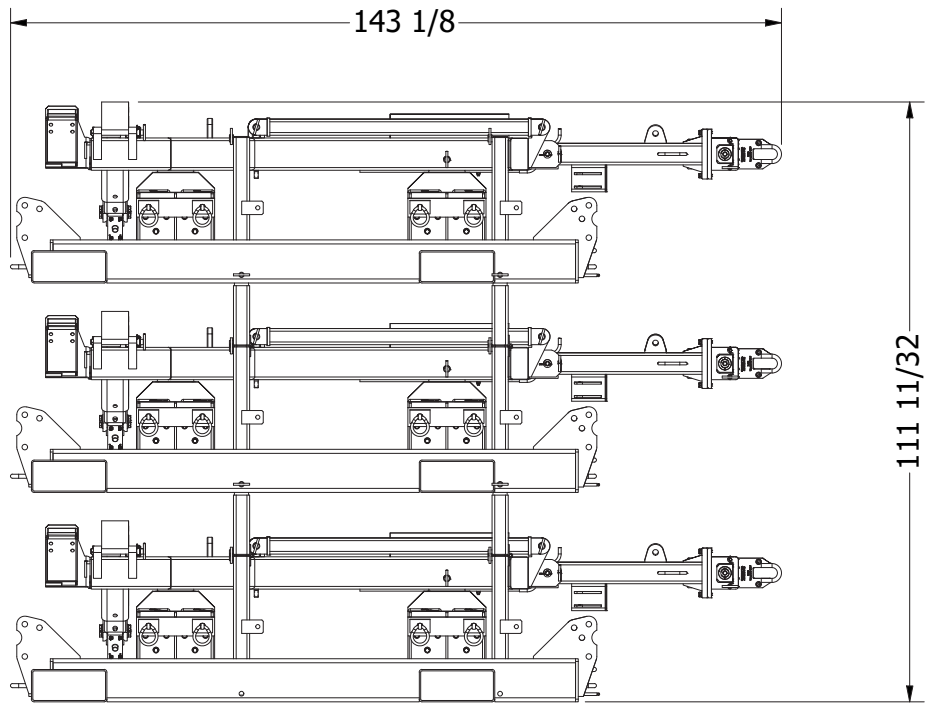

Figure 3.5-4

---

---

# 4.0 – Maintenance and Inspection

---

---

## 4.1 General

Life expectancy of this unit can be extended if it is properly maintained. By design, there is only minimal periodic servicing required. Annual inspections for damage, weld cracks, or corrosion are recommended. Prior to each use, the stand should be inspected for obvious signs of abuse or shipping damage. Observed damage should require complete inspection of the affected area to ensure stand integrity is not compromised.

## 4.2 Cleaning and Painting

The stand should be cleaned with a soap and water solution and rinsed thoroughly.

Damaged paint should be touched-up with Skydrol resistant high-grade enamel paint. Superficial scratches are expected during normal usage and will not affect function.

## 4.3 Scheduled Service

All non-painted machined surfaces should be coated with a light grade oil spray every 90 days. Spray with rust inhibitor LPS-3 (MIL-C-16173D, Gr. 2) or equivalent.

## 4.4 Scheduled Inspection

### CAUTION

**Prior to each use, the stand should be inspected for obvious signs of abuse or shipping damage. Observed damage should require complete inspection of the affected area to ensure stand integrity is not compromised.**

Annual inspections of machined surfaces, pins, fasteners, structure and shock mounts are recommended. The machined surfaces (wheels, axles, pivots) are to be visually inspected for signs of wear or corrosion. Action is to be taken immediately if areas are determined to be potentially dangerous to operating personnel, or a detriment to the equipment. Pins and fasteners are to be visually inspected for cracks, damage, or corrosion. Loose fasteners should be tightened. The structure is to be visually inspected for damage, weld cracks, or corrosion.



## CAUTION

**AGSE recommends that shock mounts be replaced every five (5) years. Additionally, periodic inspections should be performed and any of the following conditions are proper cause for replacement of the shock mounts prior to their expiration:**

- 1. Visible evidence of cracks.**
- 2. Discoloration: visible damage caused by solvents.**
- 3. Permanent deformation.**
- 4. Mount does not flex during engine loading/unloading.**
- 5. Significant corrosion on shock attach-plate.**

The following exposures can reduce the life of shock mounts and it is recommended to avoid them where possible.

- High humidity and/or salty air
- Direct sunlight
- Solvent, corrosive liquids, and fumes
- Oils, jet fuel, or Skydrol hydraulic fluid
- Extreme temperatures
- Ozone or engine exhaust

## 4.5 General Maintenance Schedule

**NOTE:**

This Maintenance Schedule does not supersede the maintenance described in Customers' Company Maintenance Policy. Intervals indicated are recommendations only and should be altered to take into consideration usage factors and environmental conditions.

Component	Task to be Performed	Maintenance Intervals			
		Monthly	3 Months	6 Months	Yearly
<b>General</b>	Inspect for missing parts	1*			
	Inspect paint/plating finish			I	
	Inspect exposed/bare metal for rust		H		
	Function check equipment				2*
	Inspect all stencils/placards/stamps			I	
<b>Casters</b>	Check wheel condition			I	
	Tighten mounting bolts			T	
	Check swivel lock/brake			I	
	Lubricate bearings			L	
<b>Structure</b>	Inspect frame for damage/cracked welds			I	
	Tighten all bolts		T		
	Lubricate/protect moving joints		H	L	
<b>Pins</b>	Inspect for damaged/bent/worn pins			I	
	Inspect for broken/cracked pin handles			I	
	Inspect for broken/cut lanyards			I	
<b>Engine Mounts</b>	Apply Anti-seize to engine bolt threads	L			
	Lubricate/protect sliding pins	L			
<b>Shock Mount</b>	Check date				3*
	Inspect rubber for cracking/deformation			I	
	Inspect for permanent set/deformation			I	
<b>Manual</b>	Check manual is present/readable			4*	
	Check manual revision is current				5*

1\* - Inspection for missing parts before every use.

2\* - Carry out function test if equipment has not been used for extended period of time.

3\* - Shock isolator manufacturer recommends that isolators be changed every 5 years.

4\* - Check that manual is present before every use.

5\* - Latest manuals are available from [www.agsecorp.com](http://www.agsecorp.com) or call (562) 906-9300

**Legend**

I - Inspect/Check

T - Tighten

L - Lubricate

H - Spray with rust inhibitor

R - Replace Recommended Lubricant: Chevron Dura-Lith Grease EP, NLGI2 or equivalent.

---

---

# 5.0 – Operation

---

---

## 5.1 Engine Installation into Stand

<b>CAUTION</b>
----------------

**Stainless steel pins of various sizes are widely used with this equipment. All are retained by a cable lanyard, which terminates in a spring safety clip. Stowage is provided for all pins when not engaged, either in their normal position or nearby, and they should always be stowed. Failure to do so may cause tangling, breaking of the lanyards, and loss of pins.**

- 1) Inspect stand for obvious damage.
- 2) Ensure the base and cradle are pinned together.
- 3) Remove the AGSE-E25960-S01 LH fixed FWD mount assembly and RH adjustable AGSE-E25960-S02 FWD mount assembly from the cradle by removing the AM-90750-64T safety pins (2) (Figure 5.1-1).
- 4) Remove the AM-90500-41T safety pin to pivot open the AM-E25949-P01 AFT mount saddle cap on the AGSE-E25948-S01 LH fixed AFT mount assembly to remove the AGSE-E25948-S01 LH fixed AFT mount spindle assembly from the cradle (Figure 5.1-1). (If the mounts are not installed on the cradle, they can be found in the mount container.)
- 5) Remove the AM-90500-41T safety pin to pivot open the AM-E25949-P01 AFT mount saddle cap on the AGSE-E25948-S02 RH adjustable AFT mount assembly to remove the AGSE-E25948-S02 RH adjustable AFT mount spindle assembly from the cradle. (Figure 5.1-1). (If the mounts are not installed on the cradle, they can be found in the mount container.)

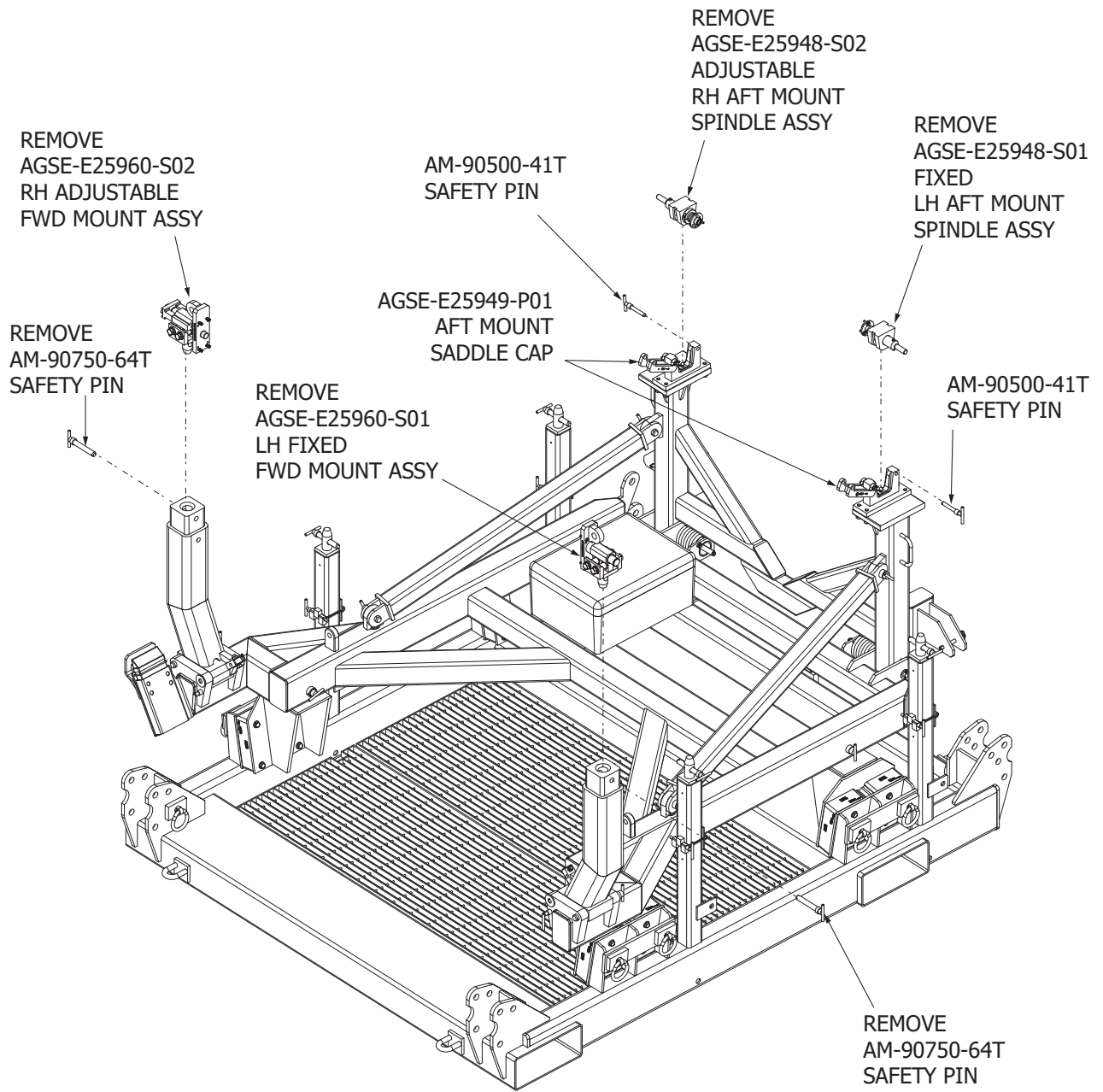

Figure 5.1-1

- 6) Install the AGSE-E25960-S01 fixed LH FWD mount assembly and AGSE-E25960-S02 adjustable RH FWD mount assembly on the FWD engine ground handling mounts using eight (8) 90128A753 hex head cap screws and eight (8) 5/16" lock washers. Apply Anti-seize thread lubricant to bolt threads before installing into the engine. (Illustration Figure 5.1-2).
- 7) Install the AGSE-E25948-S01 fixed LH spindle assembly and AGSE-E25948-S02 adjustable RH spindle assemblies on the AGSE-E26207-P01 (LH) and AGSE-E26207-P02 (RH) AFT engine mounts using 3 each (per side) hex bolts, flat washers and lock washers. Apply Anti-seize to bolt threads before installing into the engine mounts.
- 8) Install the AGSE-E26207-P01 and AGSE-E26207-P02 AFT engine mounts on the engine AFT ground handling mounts using the hardware provided. Apply Anti-seize to bolt threads before installing into the engine. (Illustration Figure 5.1-2).

#### **NOTE**

1. **The FWD mounts should be 1.25" from the outboard face of the engine mount plate to the inboard face of the "U" bracket (Illustration Figure 5.1-4). Right hand adapter is adjustable to center engine between supports.**
  2. **The AFT mounts should be 1.95" from the outboard face of the engine mount plate to the inboard face of the "V" block. (Illustration Figure 5.1-4). Right hand adapter is adjustable to center engine between supports.**
  3. **Adjust set collar by loosening set screw and threading set collar to free of support.**
- 9) Position the stand beneath and centered to the suspended engine.

#### **CAUTION**

**Minimal clearance exists between the engine and stand. The operator is responsible to ensure the engine does not contact the stand.**

#### **WARNING**

**Care must be taken when working near suspended loads. Personnel should never stand beneath the suspended load.**

- 10) Slowly lower the engine until the FWD mount adapters are aligned with the receptacles on the cradle.
- 11) Continue to lower the engine until the AFT mount trunnions and the AFT mount blocks are aligned with the saddles on the AFT mounts.
- 12) Continue to lower the engine until the AFT mount trunnions and the AFT mount blocks are fully seated in the saddles of the AFT mounts. Install the AFT mount caps and secure with the safety pins and the hold-down pins.
- 13) Adjust set collar on AGSE-E25948-S02 adjustable RH AFT spindle and adjust set screw on AGSE-E25960-S02 adjustable RH FWD mount so all connections are snug. (Illustration Figure 5.1-4.)
- 14) Lower the engine until the engine weight is fully supported by the stand.
- 15) Remove the engine sling.

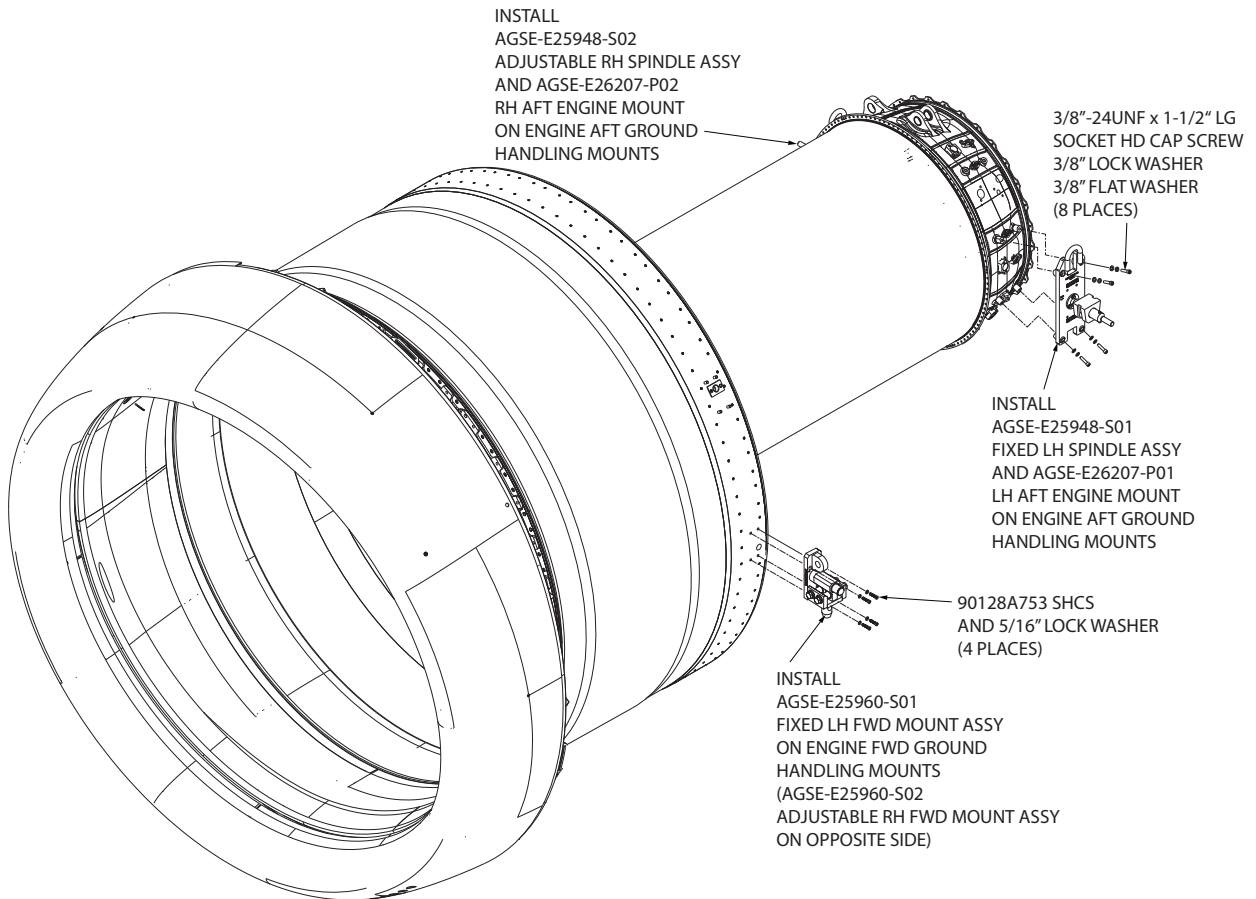
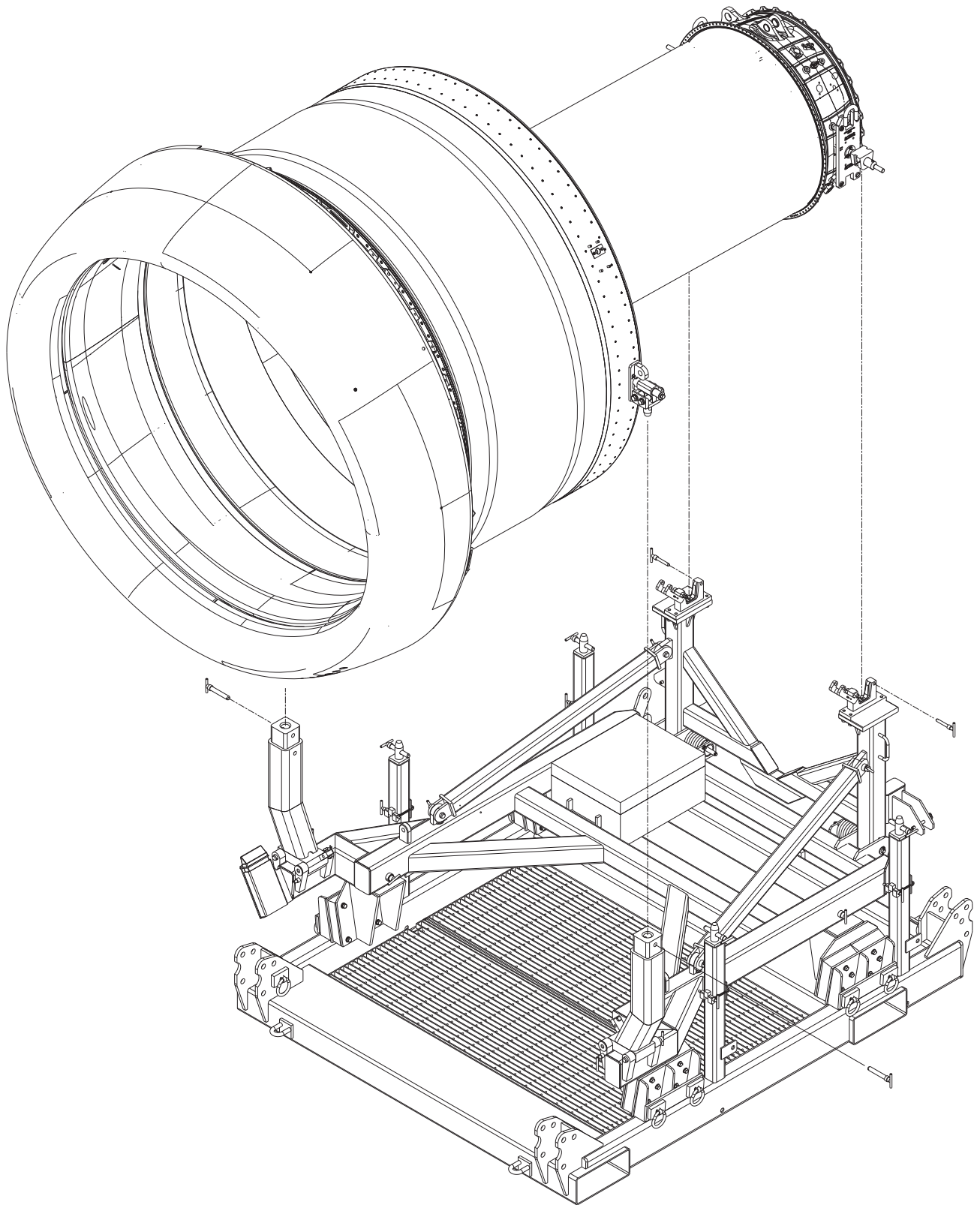
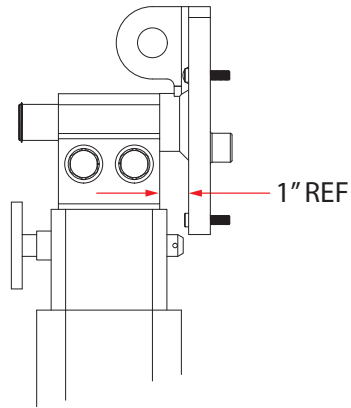

Figure 5.1-2



*Figure 5.1-3*



FIXED FWD MOUNT - LH

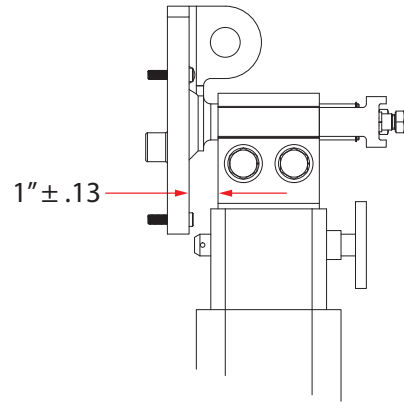

ADJUSTABLE FWD MOUNT - RH

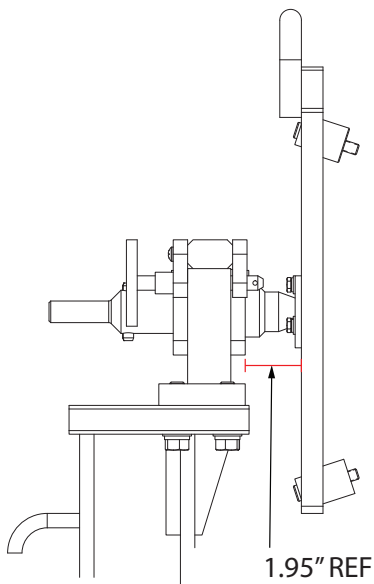

FIXED AFT MOUNT - LH

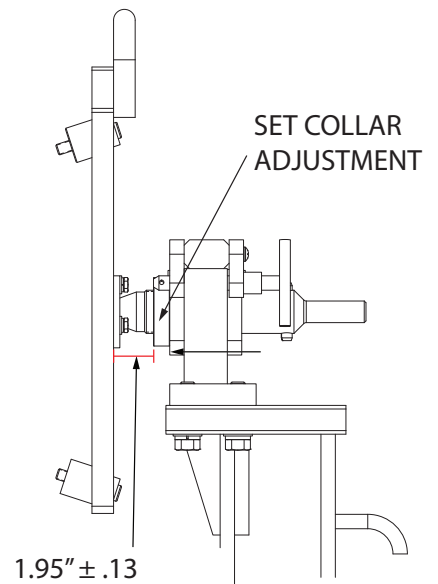

ADJUSTABLE AFT MOUNT - RH

**VIEW AFT LOOKING FWD**

*Figure 5.1-4*



## 5.2 Stowing the Cradle for Stacking and Transport

### 5.2.1 Stowing the Cradle

- 1) Remove two (2) AM-90750-64T safety pins to remove the AGSE-E25960-S01 LH fixed FWD mount assembly and AGSE-E25960-S02 RH adjustable FWD mount assembly. Store in AGSE-E26297-S01 component storage box. (Illustration Figure 5.2-1).
- 2) Remove two (2) AM-90500-41T safety pins from AGSE-E25949-P01 AFT mount saddle caps to remove the AGSE-E25948-S01 / AGSE-E26207-P01 LH fixed AFT mount spindle assembly and AGSE-E25948-S02 / AGSE-E26207-P02 RH adjustable AFT mount spindle assembly and store in the component storage box.
- 3) Close the two (2) saddle caps and secured on the AFT mount bases with the removed safety pins AM-90500-41T.
- 4) Remove two (2) safety pins AGSE-E25902-P01 from the frame weldment storage location.
- 5) Remove two (2) rear AM-91000-34T safety pins to pivot down the two (2) AGSE-E25908-P01 AFT braces. Secure with the two (2) removed AM-91000-34T safety pins on the cradle lugs as shown in Illustration Figure 5.2-2.
- 6) Pivot the AGSE-E25906-P01 frame weldment down until the stowage hole is aligned with that on the cradle frame. Secure with AGSE-E25902-P01 safety pin.
- 7) Remove two (2) AM-90500-128L safety pins from their storage location.
- 8) Remove two (2) AM-91000-128T safety pins.
- 9) Pivot down the two (2) AGSE-E25935-P02 FWD mounting legs until the stowage holes are aligned with those on the cradle frame and install previously removed two (2) AM-90500-128L and two (2) AM-91000-128T safety pins.

### **CAUTION**

**The front mounting legs are heavy (approximately 85 lbs.) and require two or more people to raise or lower. Use care to avoid muscle strain or pinch points.**

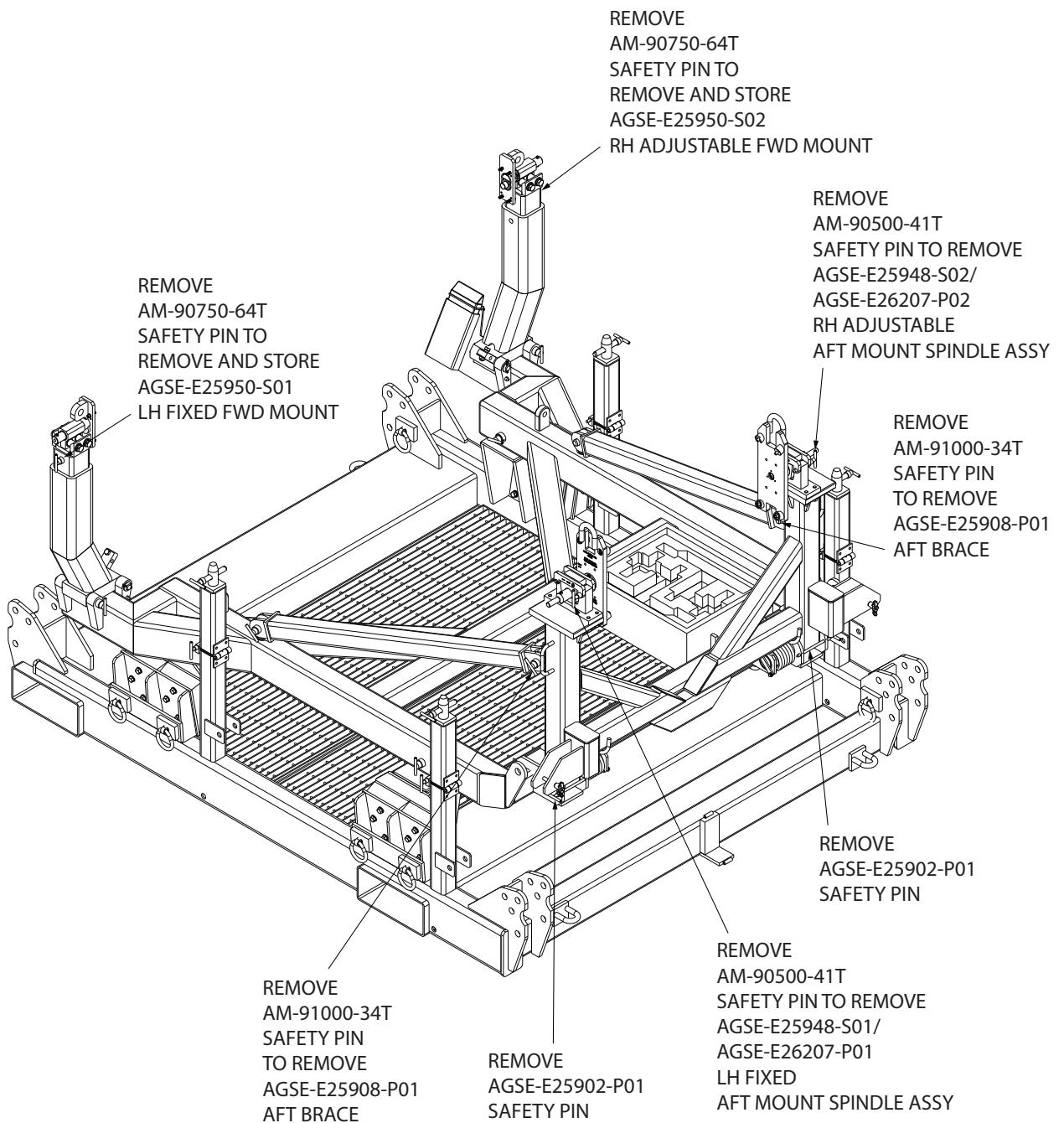

Figure 5.2-1

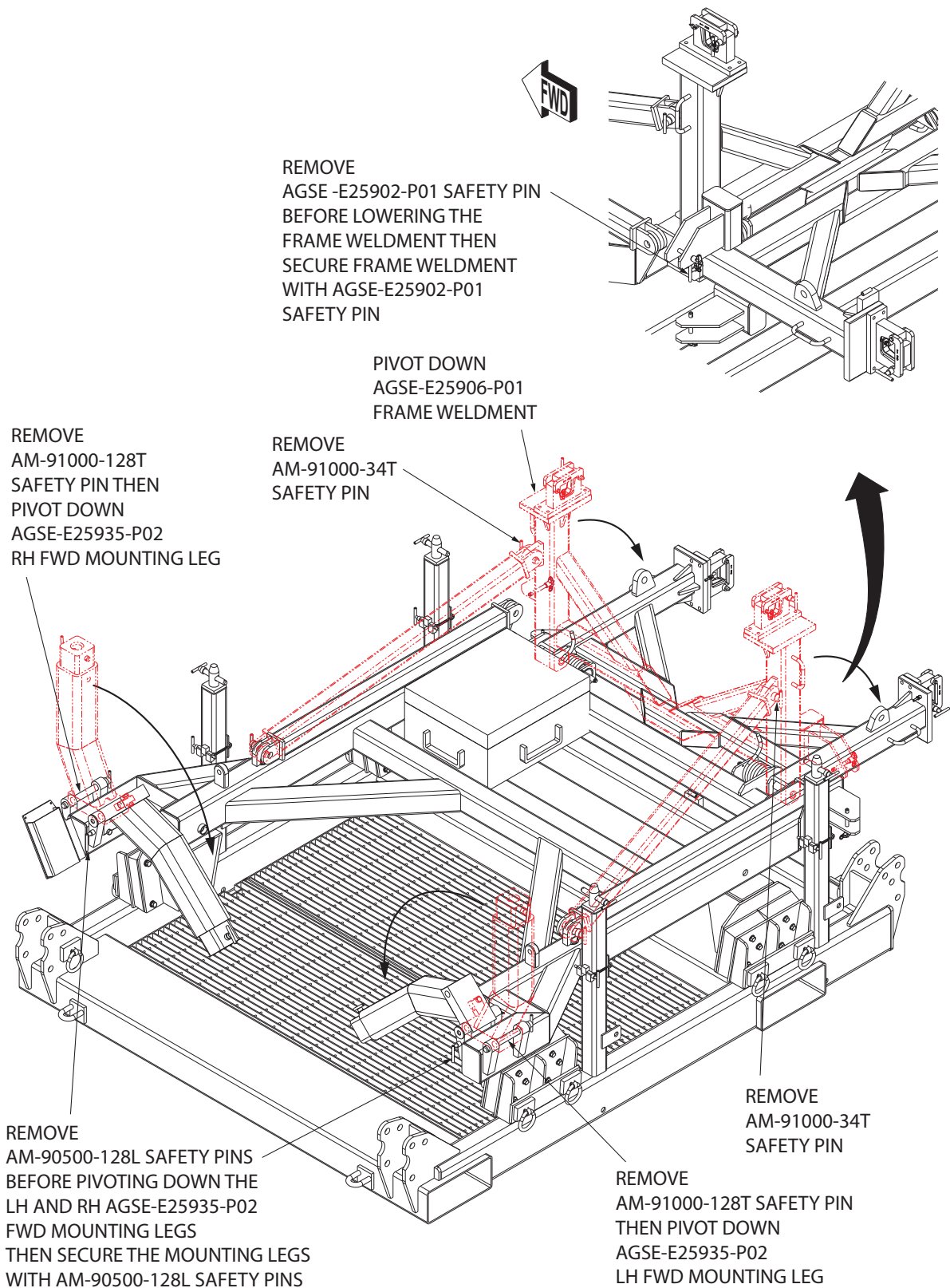

Figure 5.2-2

### 5.2.2 Stacking (Illustration Figure 5.2-3)

See Section 5.2.1 to prepare the stands for stacking.

#### **CAUTION**

**The maximum recommended stackability for transportation or storage is three (3) stands high.**

- 1) An overhead hoisting system or a fork lift can be used to lift the upper stand.
- 2) On the lower stand, deploy the stacking posts by removing the AM-90750-64T safety pin from the storage lugs, and rotating them upwards. Secure the stacking posts in the upright position using the AM-90375-48T safety pins with the T-handle facing inboard.

#### **NOTE**

**The stacking posts on the top stand are to be maintained in the stowed (lowered) position.**

- 3) Slowly lower the upper stand onto the lower stand.
- 4) Make necessary adjustments to align the upper stand's four (4) mounting holes at the bottom of the base frame with the lower stand stacking posts.
- 5) Secure the upper stand with four (4) AM-90750-64T safety pins.

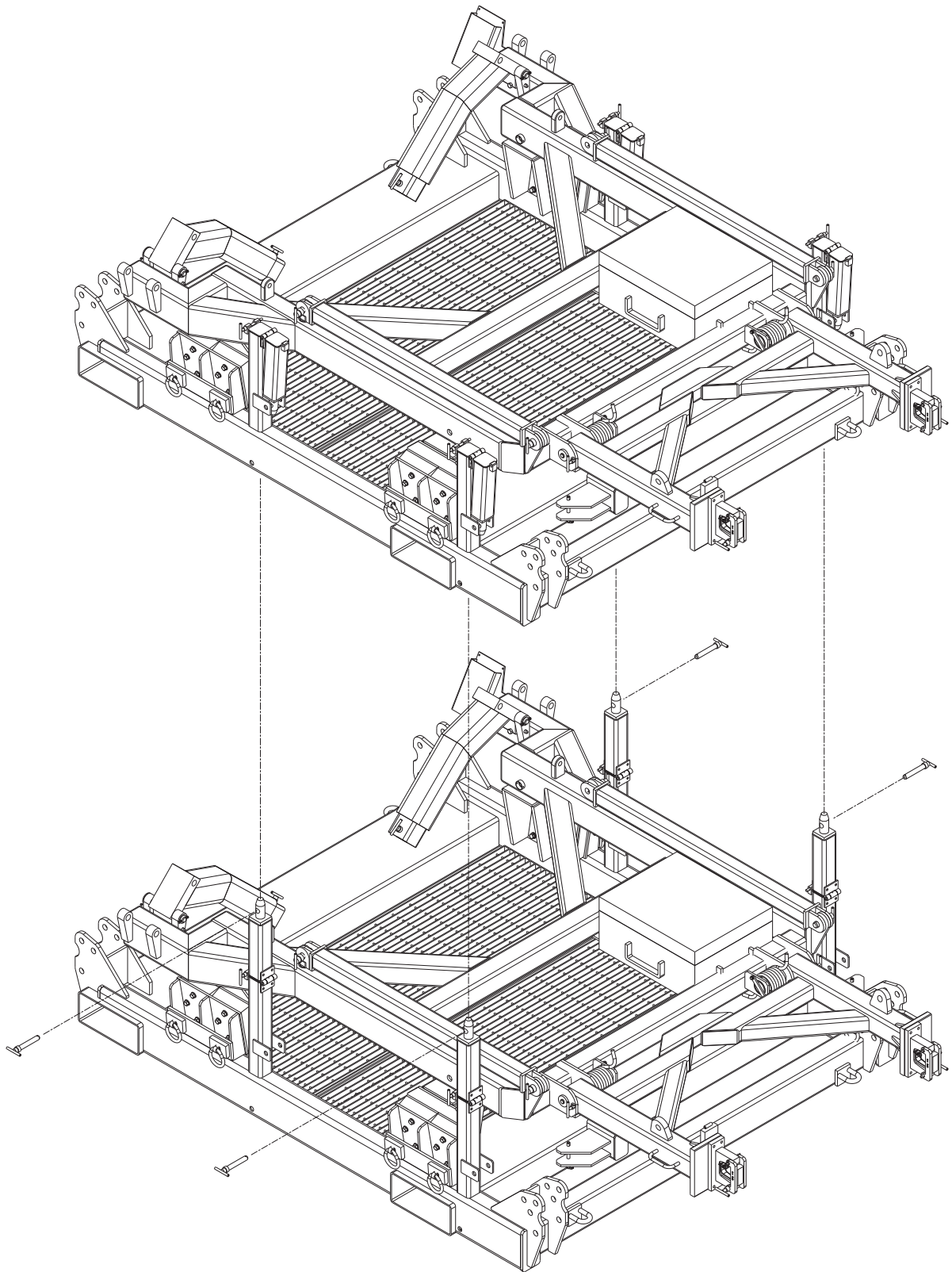

*Figure 5.2-3*

### 5.3 Truck Tie-Down (Illustration Figure 5.3-1)

#### **CAUTION**

The cradle must never be tied directly down to the truck bed. Truck shipment using a truck trailer equipped with an “air-ride” type suspension system is mandatory.

#### **CAUTION**

DO NOT tie-down above the shock mounts. Doing so will disable the shock mount system and will result in engine damage.

#### **NOTE**

The tie-down rings are rated at 10,000 lbs. capacity.

#### 5.3.1 Air Shipment

The tie-down procedures for air shipment should be done in accordance with the aircraft weight and balance manual and at the discretion of the cargo loadmaster.

#### 5.3.2 Truck Shipment

Secure the transport base to the truck bed at the discretion of the cargo handler. Secure the loaded base to the truck bed using chains (10,000 lbs. capacity minimum) and nylon straps (5,000 lbs. capacity minimum) per the following diagram.

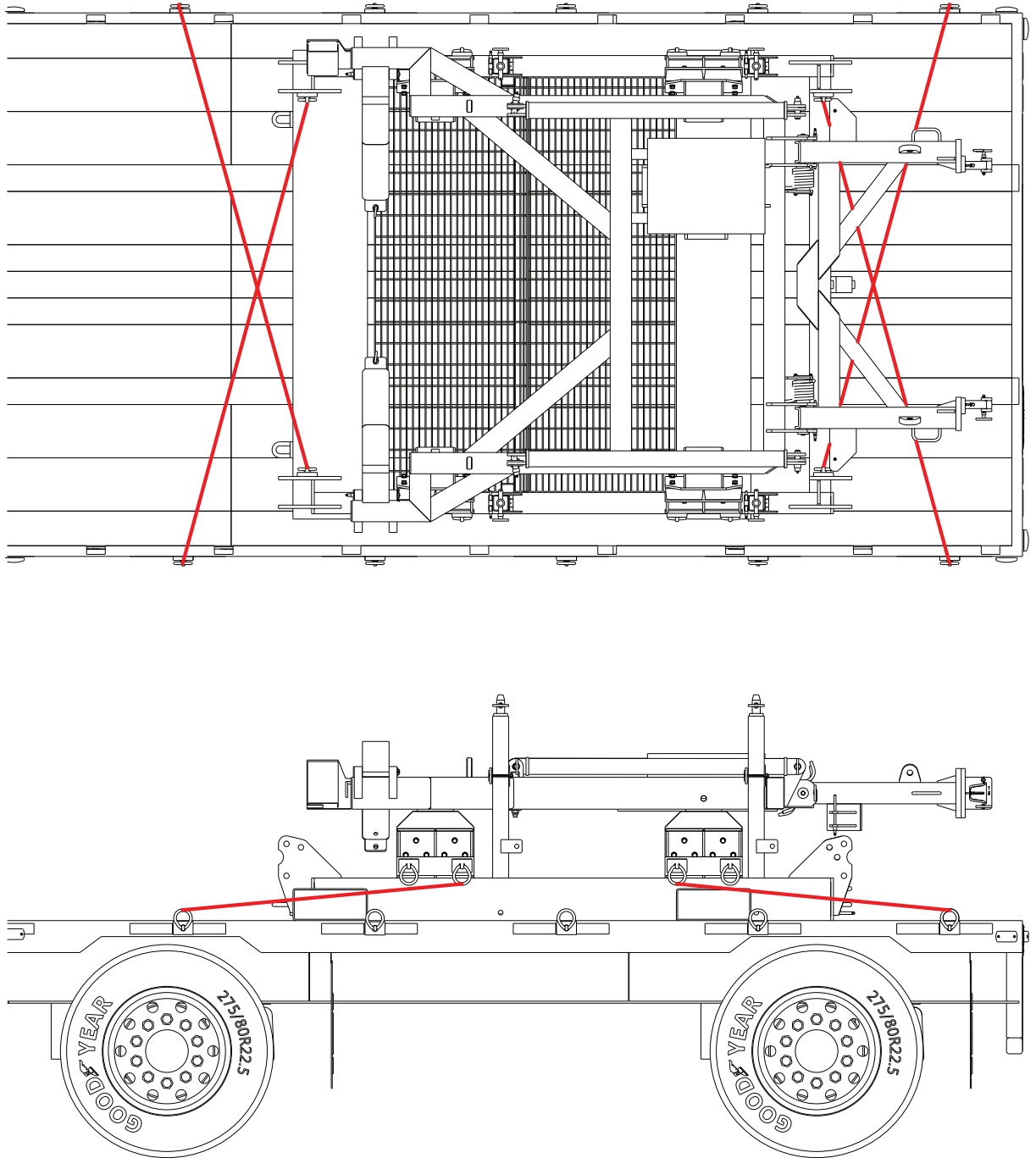

*Figure 5.3-1 Truck Tie-Down*

---

---

# 6.0 – SAFETY

---

---

## 6.1 Stress

Design stress safety factors are compliant with PW PPS 1778. The equipment is provided with safety devices and guards to properly operate the equipment.

## 6.2 General

Most accidents are the result of violating standard safety rules in operation or improper servicing and maintenance of equipment.

Many safety features have been incorporated into the design to assist in safe operation of this equipment. These items do not fool-proof the equipment nor do they replace the operator's responsibility to operate the equipment in a safe manner.

### CAUTION

**Any deficiency revealed through inspection must be reported to supervisory personnel. A determination must be made prior to resuming operation, as to whether the deficiency constitutes a safety hazard to personnel or equipment.**

It is the operator's responsibility to report any deficiencies, unusual noises, or operating conditions to supervisory personnel. It is also the responsibility of the user of this equipment to discontinue use until they are assured that the deficiency has been corrected.

## 6.3 Prevention

A good preventative maintenance program should include periodic lubrication, adjustment, and immediate correction of defects revealed through inspections. Preventive maintenance will not only contribute to safe operation, but will also extend useful service life as well.

## 6.4 Risk Assessment

### 6.4.1 Limits of the Machinery

The AGSE-E259-G03 (PWA211330 REV B) Engine Transport Stand is a commercial product designed specifically only to store and/or transport the Pratt & Whitney PW1130G engine in QEC configuration. The equipment is to be used only by trained mechanics free from physical impairment and who are familiar with this or similar fixture. The equipment is not to be used or made available to the general public.



## 6.4.2 Risk Assessment and Residual Risk

The risk evaluation performed was based on objective observation based on the experience of AGSE with similar equipment. Necessary Warning and Caution Notes have been incorporated into the Operation Section of the PW1130G Engine Transport Stand Operation Manual along with instructions. Stencils also have been put on the equipment to identify hazardous and/or potential risk areas.

The operation of the AGSE-E259-G03 Engine Transport Stand can be with medium risk of injury and is considered safe to use under supervision. Low residual risks include potential pinch points during operation of the equipment.

Equipment detailed in this manual has undergone stringent safety analyzing using methods and standards set forth within European Standard EN 1050 and is considered to be safe for its intended use. Reports on risk analysis and evaluation according to 2006/42/EC Machinery Directive (17 May 2006) are available upon request.



## ***EC DECLARATION OF CONFORMITY***

The machinery listed below fulfills all relevant provisions of the directives listed:

- 2006/42/EC Machinery Directive (2006/05/17)

Machinery covered by this Declaration:

Description: Engine Transportation Stand, PW 1130G  
Model: AGSE-E259  
Part Number: AGSE-E259-G03 (PWA211330 REV B)  
Serial Number: \_\_\_\_\_

Harmonized Standards:

- ISO 12100:2010 Safety of Machinery - General Principles for Design - Risk Assessment and Risk Reduction
- ISO/TR 14121-2:2012 Safety of Machinery - Risk Assessment - Part 2: Practical Guidance and Examples of Methods

Standards and Specifications:

- Pratt & Whitney GSE Specification No. 3027, Full Engine Production Transport Stand for the PW1900G Engine, 2013/10/07
- AGSE Quality System Procedure Number QSP-006
- Aerospace Recommended Practice Standard, SAE ARP 1840, 2007/02 Rev B

Place: Santa Fe Springs, California, USA

Date: \_\_\_\_\_

Signed: \_\_\_\_\_  
Quality Representative

Technical File: Pedro Fernandes  
Advanced Ground Systems Engineering  
Pct Ana Maria Bastos, N20  
A-dos-Cunhados, Portugal 2560-005  
+351-96-520-4851

---

---

# 7.0 – Warranty

---

---

## 7.1 Statement of Warranty

Advanced Ground Systems Engineering LLC (AGSE) warrants to original purchasers that its products will be free of defects in material and workmanship under normal use and conditions for claims received within a period of one year from date of purchase (final billing date), and to the extent that if any AGSE product fails in operation because of such defect, the company will replace or repair, at its option, the defective article. Prior to the repair or replacement of any defective product, the company shall be notified in writing as to the nature of the defect. The company shall assume no liability for freight, disassembly, removal, refitting and installation charges on any article returned unless such charge(s) is approved by AGSE in writing prior to the return. On component items purchased by AGSE for incorporation into an AGSE manufactured product, only the component manufacturer's warranty (if any) shall apply to that component. Said manufacturer's warranty shall be passed on to AGSE's customer to the extent permitted. This warranty is applicable only when AGSE products are operated for intended purposes within the recommended procedures, load limits, properly maintained, not damaged or abused, etc., including as indicated in company manuals, catalogs, and drawings. All warranty claims must be applied for within sixty days from when the defect becomes known. The foregoing warranty is in lieu of all other warranties, or liabilities, either expressed or implied, and AGSE expressly excludes all implied warranties of merchantability and fitness for a particular purpose and all non-infringement warranties as well as disclaims all liabilities to third parties. In no event shall AGSE be liable for any amounts in excess of the purchase price of the product.

<b>NOTICE</b>
---------------

**Failure to conduct periodic inspections, routine maintenance, or improper operation will result in the voiding of the warranty.**

---

---

# 8.0 – Parts Breakdown

---

---

## 8.1 General

The following pages can be used in the identification of components used in the product described in this manual. Parts Lists are broken down by “ITEM,” “PART NUMBER,” “QTY,” and “DESCRIPTION.”

<b>NOTICE</b>
---------------

**“ITEM” numbers are for reference to the Illustrated Parts Breakdown (IPB) only. Do not order replacement parts by “ITEM” number. Order parts by “PART NUMBER” only.**

## 8.2 Illustrated Parts Breakdown

---

---

## IPB Figure 1 – AGSE-E259-G03 Engine Transport Stand Assembly

---

---

ITEM	PART NUMBER	QTY	PART DESCRIPTION
	AGSE-E259-G03	-	Engine Transport Stand Assy (Figure 8.1-1)
1	AGSE-E25901-S01	1	Base Assy (See IPB Figure 2 for Details)
7	03-1033-05	1	GPS Transmitter
9	AGSE-E23316-S01	1	U-Bolt Assy
10	AGSE-E25902-S03	1	Cradle Assy w/ Lifting Adapters

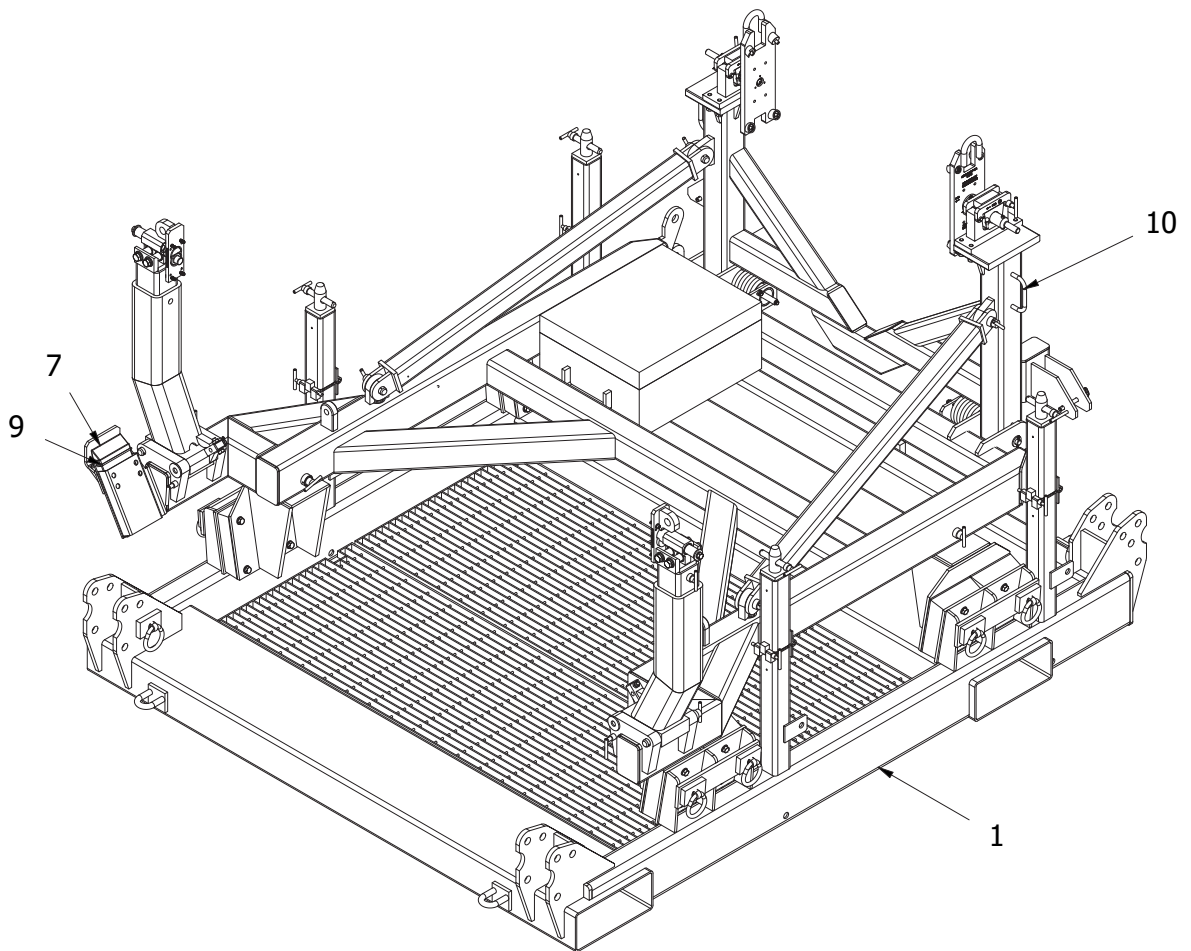

*Figure 8.1-1*

---



---

## IPB Figure 2 – AGSE-E25901-S01 Base Assembly

---



---

ITEM	PART NUMBER	QTY	PART DESCRIPTION
	AGSE-E25901-S01	-	Base Assy (Figure 8.2-1)
1	AGSE-E25904-P01	1	Base Weldment - Manual Caster
2	AGSE-E25905-P01	4	FWD Cradle Mount
4	AGSE-E25907-P01	4	Stacking Post Weldment Sub-Assy
5	AM-90375-48T	4	Safety Pin - 3/8" OD x 2-3/4" Grip
6	AGSE-S00304-P04	8	Shock Mount
7	PMP-10111	12	Tie-Down Ring - 10,000 Lbs Cap
8	AGSE-S00105-08F016A01	64	Screw, Hex Head
10	AGSE-S00131-08A17	64	Washer
11	AM-90750-64T	4	Safety Pin - 3/4" Dia. x 4" Grip

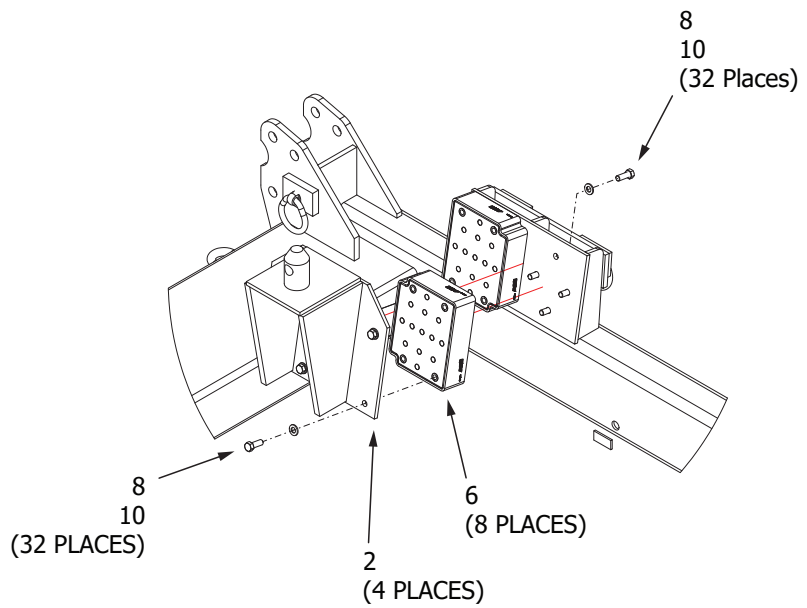
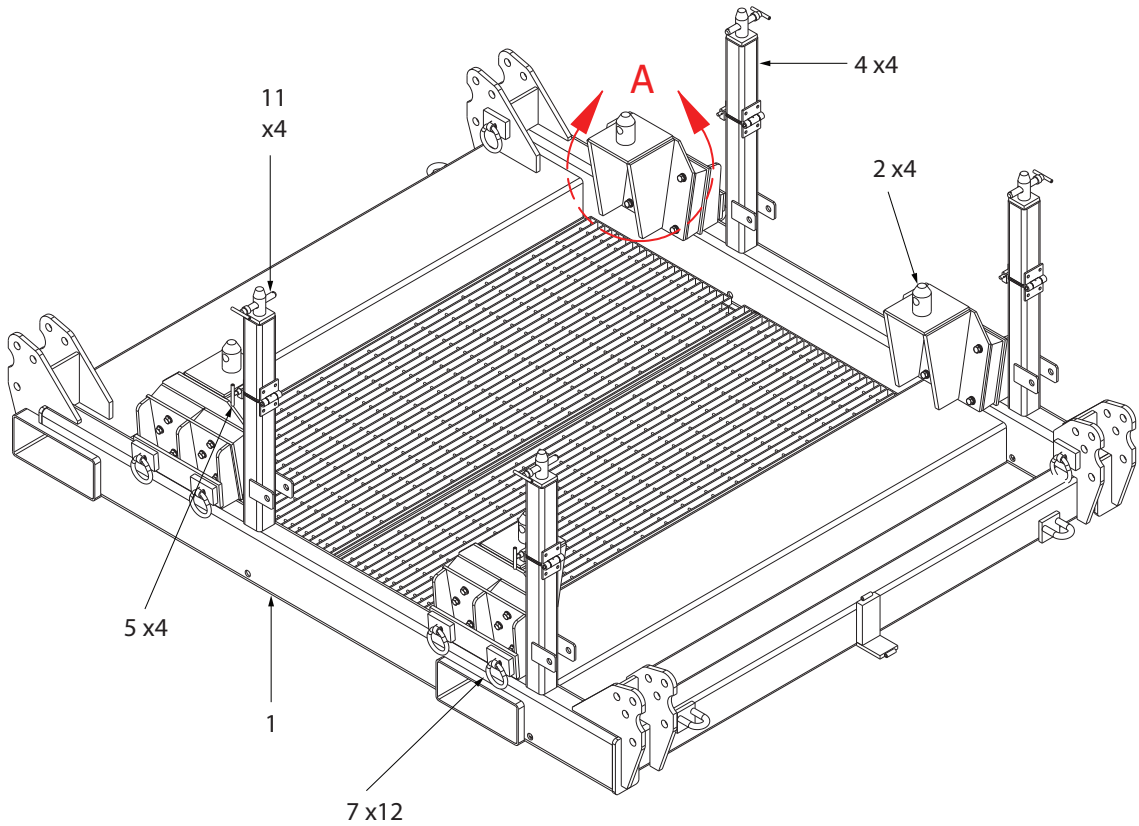

**DETAIL A**

*Figure 8.2-1*



## IPB Figure 3 – AGSE-E25902-S03 Cradle Assembly

ITEM	PART NUMBER	QTY	PART DESCRIPTION
	AGSE-E25902-S03	-	Cradle Assy (Figures 8.3-1 and 8.3-2)
2	AGSE-E25906-P01	1	Frame Weldment
3	AGSE-E25908-P01	2	AFT Brace Assy
4	AGSE-E25903-P02	1	Cradle Weldment
9	AGSE-E26297-S01	1	Storage Box Assy
14	AGSE-E26225-P01	2	Pivot Pin
16	AM-90750-64T	2	Safety Pin
17	AM-91000-34T	4	Safety Pin
27	AGSE-S00153-06CA01	8	Nut, Locking
28	92217A520	16	Washer
29	AGSE-S00166-188D024A17	4	Cotter Pin
30	AGSE-S00131-12A17	2	Washer
33	AGSE-E25935-P02	2	Front Mtg Leg
37	AGSE-E26214-P01	2	Safety Pin - 1" OD x 4" Lg
38	AM-91000-64T	2	Safety Pin - 1" OD x 4" Lg
40	AGSE-S00131-16A17	2	Washer
44	AGSE-S00131-08A17	8	Washer
49	AGSE-S00135-06A17	8	Washer, Locking
50	90128A753	8	SHCS - 5/16"-24UNF x 1-1/4" Lg
52	AGSE-S00135-04A05	8	Washer, Locking
54	AGSE-E25938-P01	2	Brace Bolt
56	AGSE-E25918-P01	2	Spring Support
57	AGSE-E26229-P01	2	Torsion Spring
58	AGSE-E25902-P01	2	Safety Pin - 3/8" OD x 5-1/2" Grip Drilled Collar
59	AM-90500-128L	2	Safety Pin - 1/2" Dia. x 8" Grip

---



---

## IPB Figure 3 – AGSE-E25902-S03 Cradle Assembly (Continued)

---



---

ITEM	PART NUMBER	QTY	PART DESCRIPTION
60	AM-91000-128T	2	Safety Pin - 1" Dia. x 8" Grip
61	AM-2811-1309	2	Plate Washer
62	AGSE-S00153-12CA01	2	Nut
63	AGSE-S00104-04C012A01	4	Screw, Hex Head
64	AGSE-S00131-04A17	10	Washer
65	AGSE-S00135-04A17	10	Washer, Locking
66	AGSE-S00118-06F024A05	8	Screw, Socket Head
67	AGSE-E26207-P02	1	AFT Engine Mount - RH
68	AGSE-E26207-P01	1	AFT Engine Mount - LH
69	AGSE-E25948-S01	1	Fixed AFT Mount Assy - LH (See IPB Figure 4 for Details)
70	AGSE-E25948-S02	1	Adjustable AFT Mount Assy - RH (See IPB Figure 5 for Details)
73	AGSE-S00139-08CA01	4	Nut
74	AGSE-S00104-08C028A01	4	Screw, Hex Head
75	AGSE-S00104-04C016A01	6	Screw, Hex Head
76	90293A414	2	Ball Lock Pin - 1/2" Dia. x 3" Grip
77	AGSE-E25939-P01	2	Pivot Pin - 1" Dia. x 8-1/4" Grip
78	AGSE-E25935-P03	1	Front Mtg Leg, RH
79	AGSE-E25953-P01	1	GPS Bumper
80	AGSE-S00114-04C010A27	4	Screw, Flat Head
81	92805K21	4	Rubber Push-On Cap
83	AGSE-E25954-P01	1	GPS Bracket Weldment
84	AGSE-S00104-04C012A01	2	Screw, Hex Head

---

---

**IPB Figure 3 – AGSE-E25902-S03  
Cradle Assembly (Continued)**

---

---

<b>ITEM</b>	<b>PART NUMBER</b>	<b>QTY</b>	<b>PART DESCRIPTION</b>
85	AGSE-S00131-04A17	2	Washer
86	AGSE-S00104-06C020A01	4	Screw, Hex Head
89	AGSE-S00104-08C032A01	8	Screw, Hex Head
90	AGSE-S00135-08A17	8	Washer, Locking
91	AGSE-E25960-S02	1	Adjustable FWD Mount Assy
92	AGSE-E25960-S01	1	Fixed FWD Mount Assy

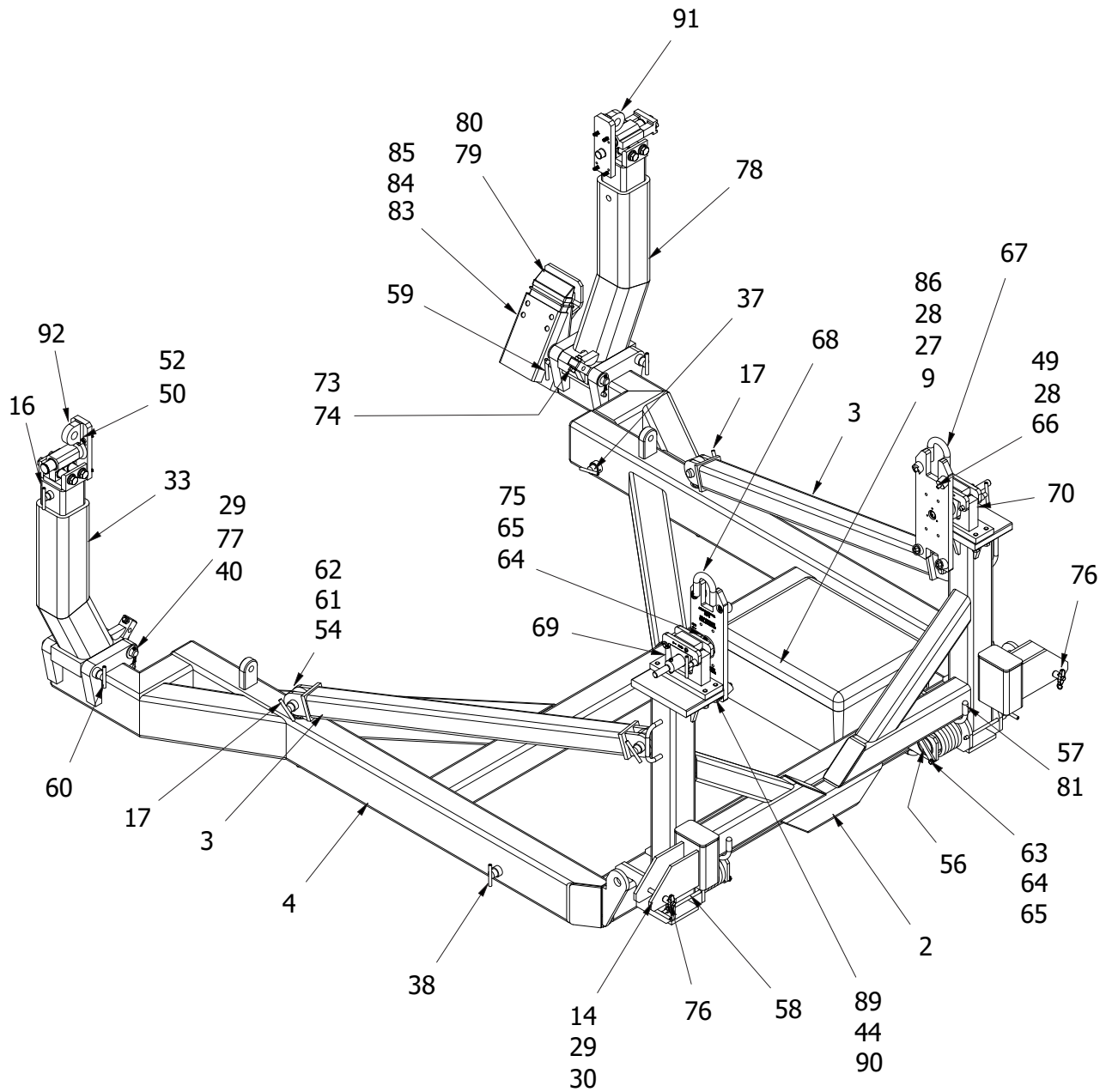

Figure 8.3-1

---



---

## IPB Figure 4 – AGSE-E25948-S01 Fixed AFT Mount Assembly - LH

---



---

ITEM	PART NUMBER	QTY	PART DESCRIPTION
	AGSE-E25948-S01	1	Fixed AFT Mount Assy - LH (Figure 8.4-1)
1	AGSE-E25948-S03	1	Fixed AFT Mount Spindle Assy - LH
2	AGSE-E22108-P01	1	Spherical Bearing (Detail of AGSE-E25948-S01)
3	AGSE-E22108-P02	1	Retainer (Detail of AGSE-E25948-S01)
4	AGSE-E25945-P01	1	AFT Mount Saddle
5	AGSE-25946-P01	1	Mount Block (Detail of AGSE-E25948-S01)
6	AGSE-E25947-P01	1	Fixed Shaft - AFT Mount (Detail of AGSE-E25948-S01)
7	AGSE-E25949-P01	1	Cap - AFT Mount Saddle
8	AGSE-E25951-P01	1	Spherical Socket Seat (Detail of AGSE-E25948-S01)
9	AM-1928-G10	1	Hold Down Pin
10	AM-90500-41T	1	Safety Pin
11	AGSE-S00115-06C008A27	1	Screw, Button Head (Detail of AGSE-E25948-S01)
12	AGSE-S00166-093D012A17	2	Cotter Pin
13	AGSE-S00170-375D032A17	1	Slotted Spring Pin
14	AGSE-S00308-04C006A17	1	Screw, Button Head
15	AGSE-S00175-08A17	2	Washer

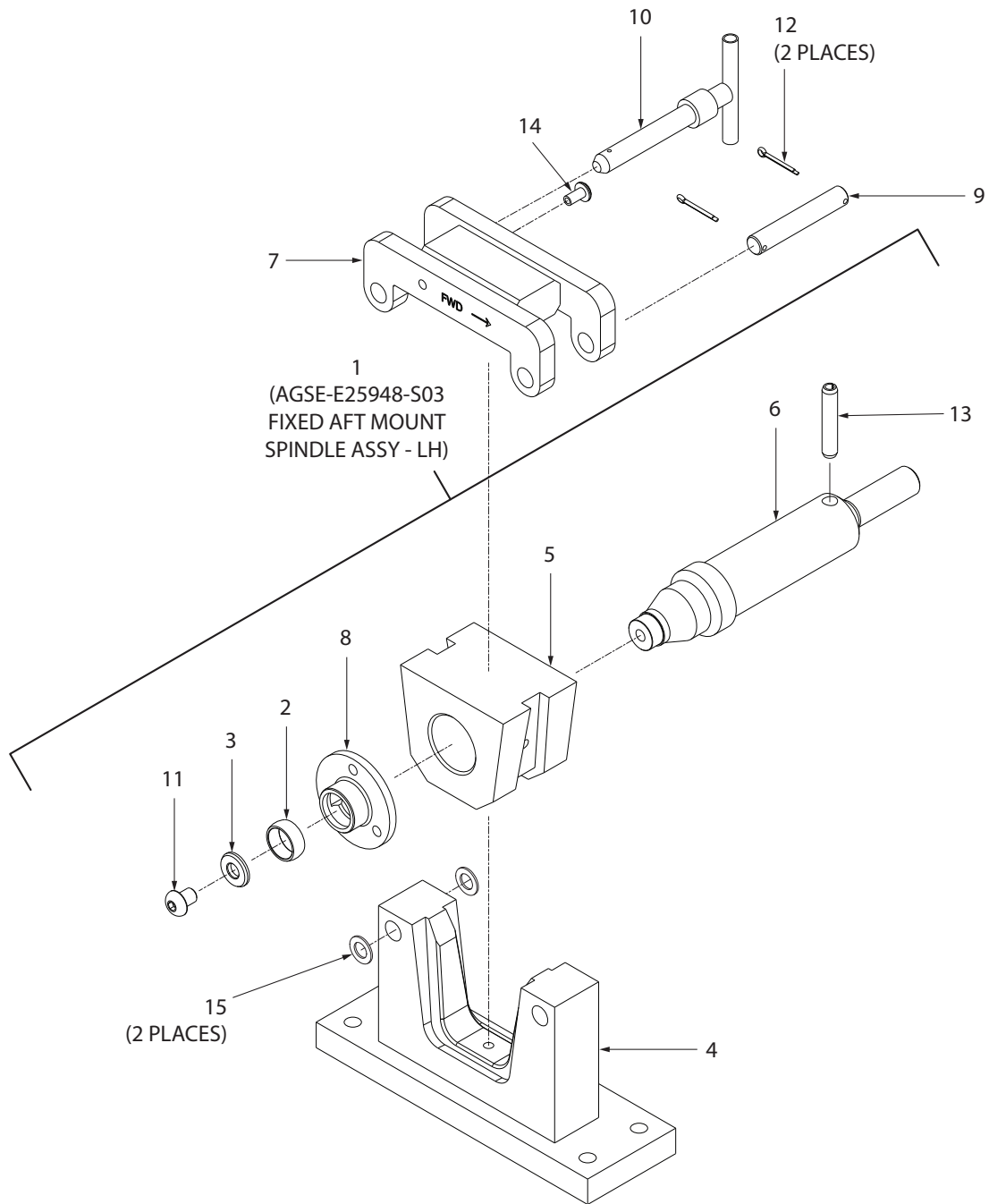

Figure 8.4-1 AGSE-E25948-S01 Fixed AFT Mount Assembly - LH

---



---

## IPB Figure 5 – AGSE-E25948-S02 Adjustable AFT Mount Assembly - RH

---



---

ITEM	PART NUMBER	QTY	PART DESCRIPTION
	AGSE-E25948-S02	1	Adjustable AFT Mount Assy - RH (Figure 8.5-1)
1	AGSE-E25948-S04	1	Adjustable AFT Mount Spindle Assy - RH
13	AGSE-E22108-P01	1	Spherical Bearing (Detail of AGSE-E25948-S02)
14	AGSE-E22108-P02	1	Retainer (Detail of AGSE-E25948-S02)
15	AGSE-E25945-P01	1	AFT Mount Saddle
16	AGSE-25946-P01	1	Mount Block (Detail of AGSE-E25948-S02)
17	AGSE-E25947-P02	1	Adjustable Shaft - AFT Mount (Detail of AGSE-E25948-S02)
18	AGSE-E25949-P01	1	Cap - AFT Mount Saddle
19	AGSE-E25951-P01	1	Spherical Socket Seat (Detail of AGSE-E25948-S02)
20	AM-1928-G10	1	Hold Down Pin
21	AM-90500-41T	1	Safety Pin - 1/2" Dia. x 2-9/16" Grip
22	AGSE-S00115-06C008A27	1	Screw, Button Head (Detail of AGSE-E25948-S02)
23	AGSE-S00166-093D012A17	2	Cotter Pin
24	AGSE-S00170-375D032A17	1	Slotted Spring Pin
25	AGSE-S00193-P05	1	Threaded Collar (Detail of AGSE-E25948-S02)
26	AGSE-S00308-04C006A17	1	Screw, Button Head (Detail of AGSE-E25948-S02)
27	AGSE-S00175-08A17	2	Washer

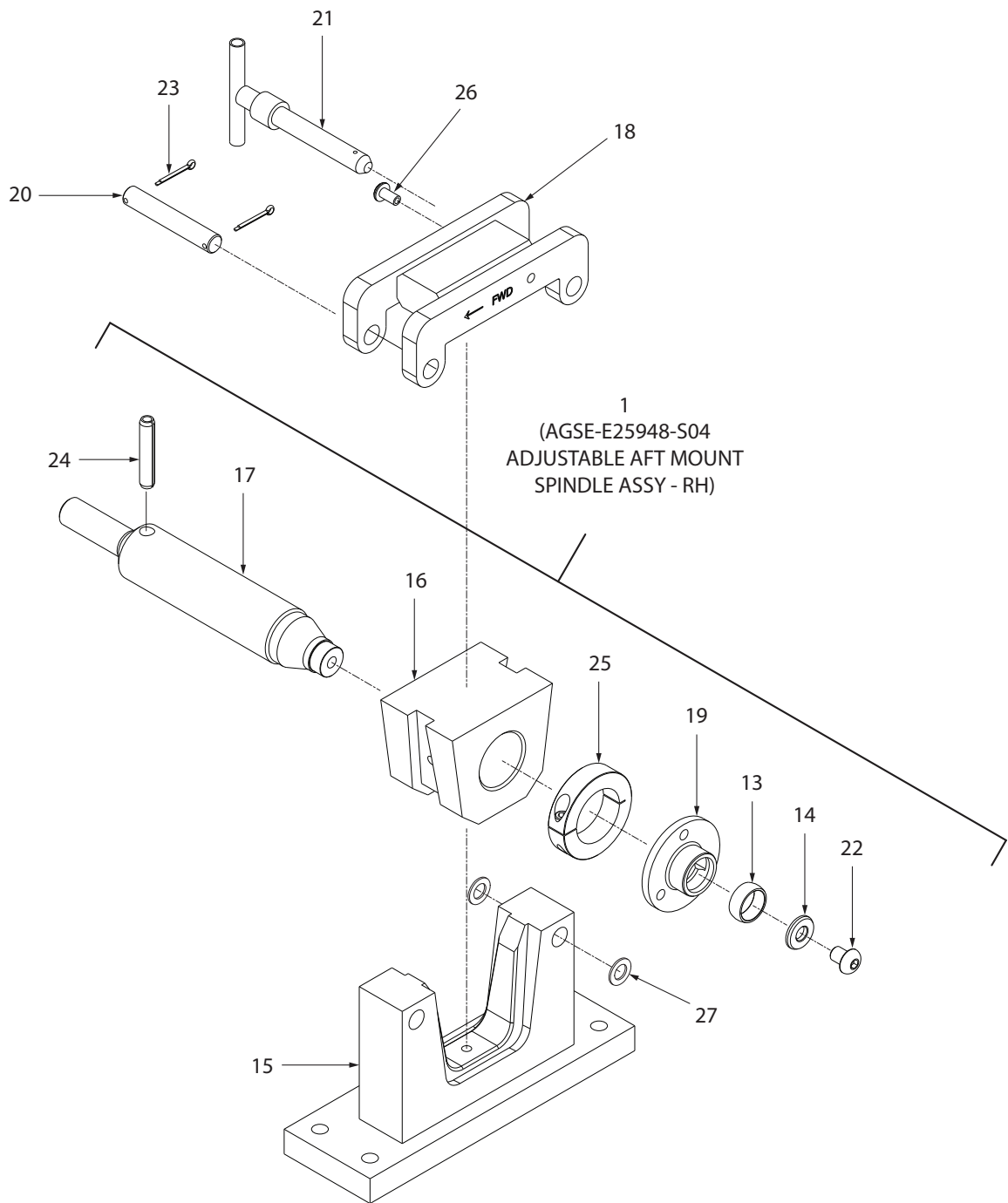

Figure 8.5-1 AGSE-E25948-S02 Adjustable AFT Mount Assembly - RH



---



---

## IPB Figure 6 – AGSE-E25960-S01 Fixed FWD Mount Assembly - LH

---



---

ITEM	PART NUMBER	QTY	PART DESCRIPTION
	AGSE-E25960-S01	1	Fixed FWD Mount Assy - LH (Figure 8.6-1)
1	AGSE-E25942-P01	1	FWD Mount Bracket Support
2	AGSE-E25950-P01	1	Slide Assy
3	AGSE-E25950-P02	2	Slide Bar
4	AGSE-E25956-P01	1	Fixed FWD Mount Adapter
5	AGSE-S00104-10C016A01	4	Spiral Retaining Ring
6	AGSE-S00104-10C016A01	4	Screw, Hex Head
7	AGSE-S00131-10A17	4	Washer
8	AGSE-S00135-10A03	4	Washer, Locking

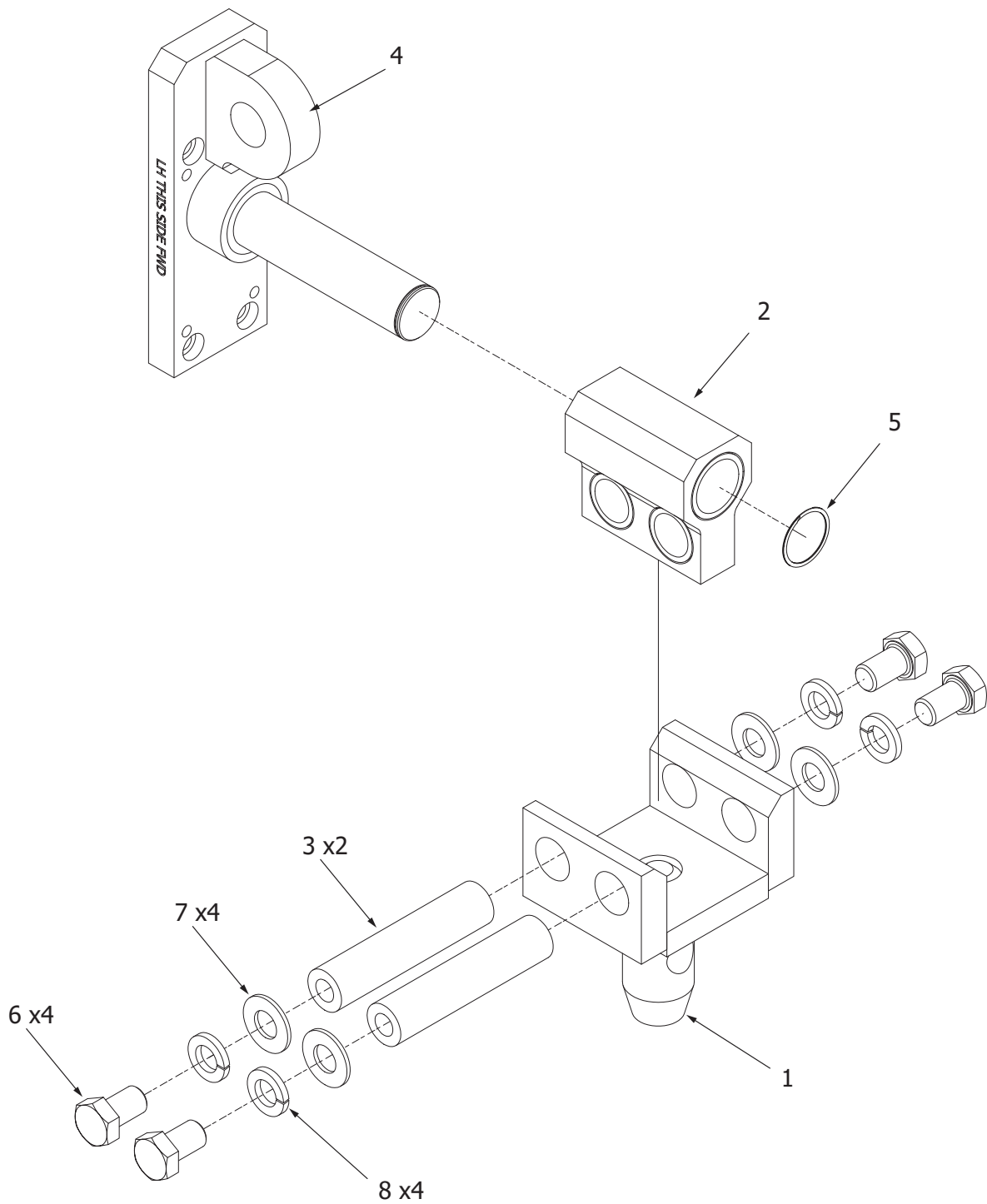

Figure 8.6-1 AGSE-E25960-S01 Fixed FWD Mount Assembly - LH

---



---

## IPB Figure 7 – AGSE-E25960-S02 Adjustable FWD Mount Assembly - RH

---



---

ITEM	PART NUMBER	QTY	PART DESCRIPTION
	AGSE-E25960-S02	1	Adjustable FWD Mount Assy - RH (Figure 8.7-1)
1	AGSE-E25942-P01	1	FWD Mount Bracket Support
2	AGSE-E25950-P02	1	Slide Bar
3	AGSE-E25956-P02	1	Adjustable FWD Mount Adapter
4	AGSE-E25957-P01	2	Slide Assy
5	AGSE-E25958-P01	1	Reaction Cap
6	AGSE-E25958-P02	1	Modified Bolt
7	93513A170	1	Spiral Retaining Ring
8	AGSE-S00104-10C016A01	4	Screw, Hex Head
9	AGSE-S00131-10A17	4	Washer
10	AGSE-S00135-10A17	4	Washer, Locking
11	AGSE-S00139-08CA01	1	Nut
12	AGSE-S00118-06C040A07	2	Screw, Socket Head
13	AGSE-S00135-06A17	2	Washer, Locking
14	AGSE-S00170-04A008A17	1	Slotted Spring Pin

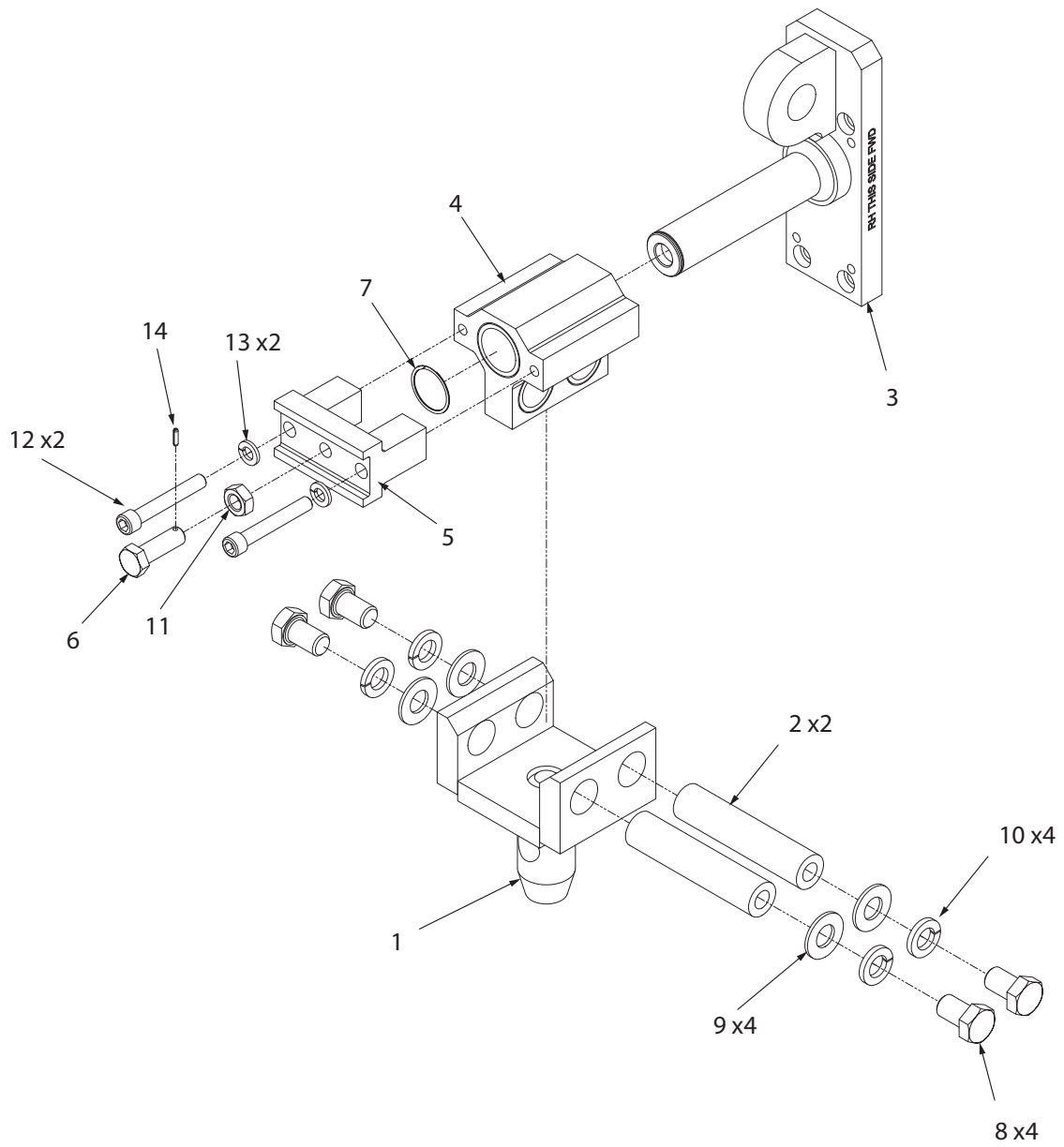

Figure 8.7-1 AGSE-E25960-S02 Adjustable FWD Mount Assembly - RH

---

---

# 9.0 – Stencils, Decals and Placards

---

---

## 9.1 General

Various stencils, decals, and placards are added to the equipment to provide warnings, cautions, and general information. These items should be reviewed and understood by maintenance and user personnel.

## 9.2 Stencils and Placards

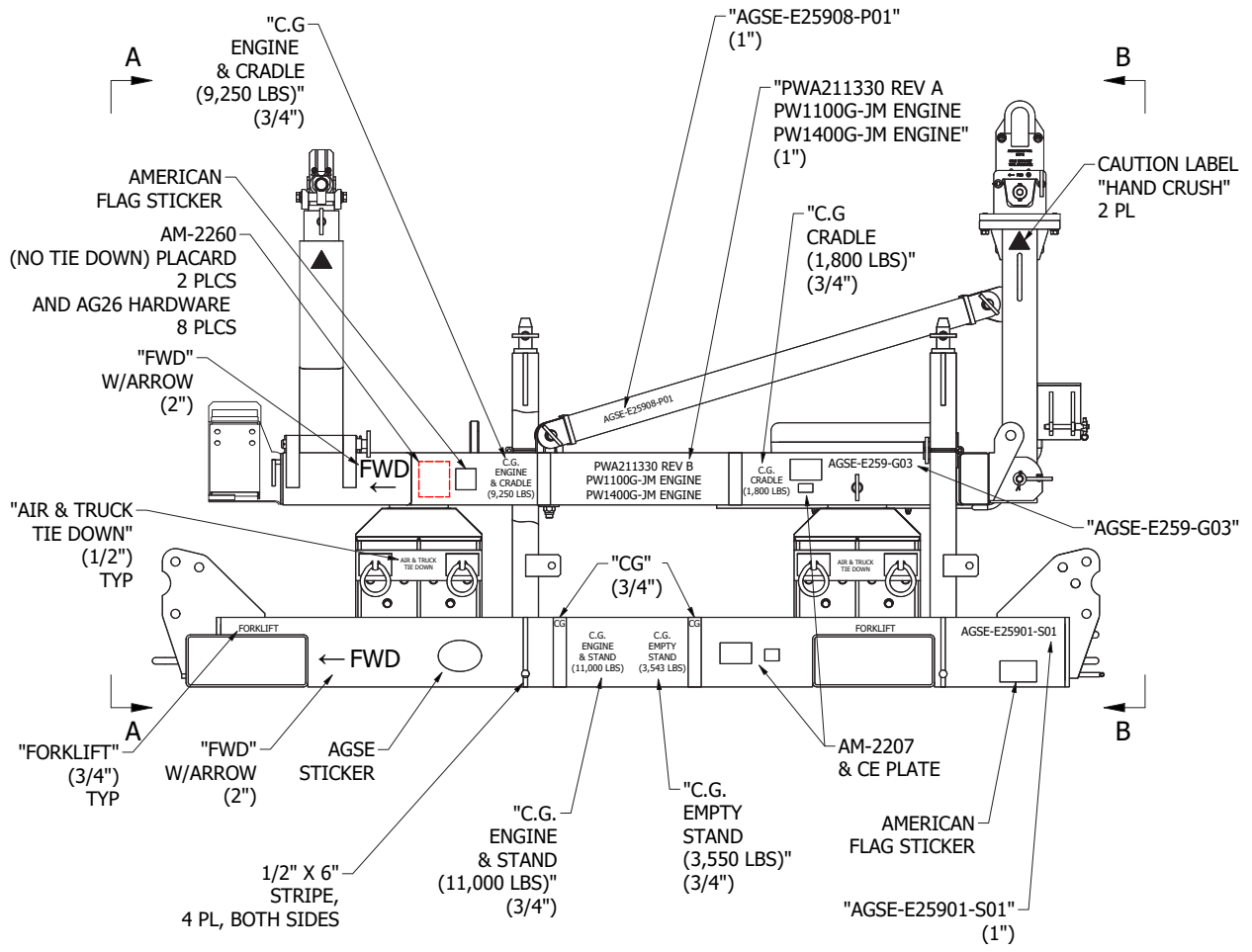
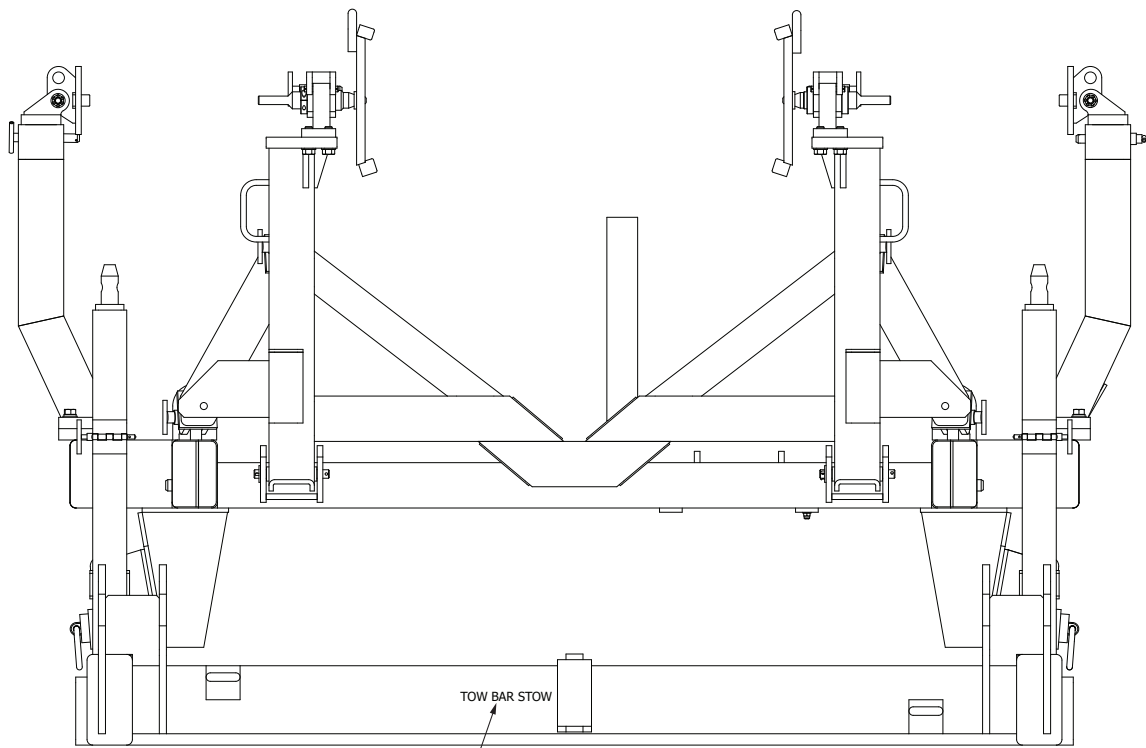
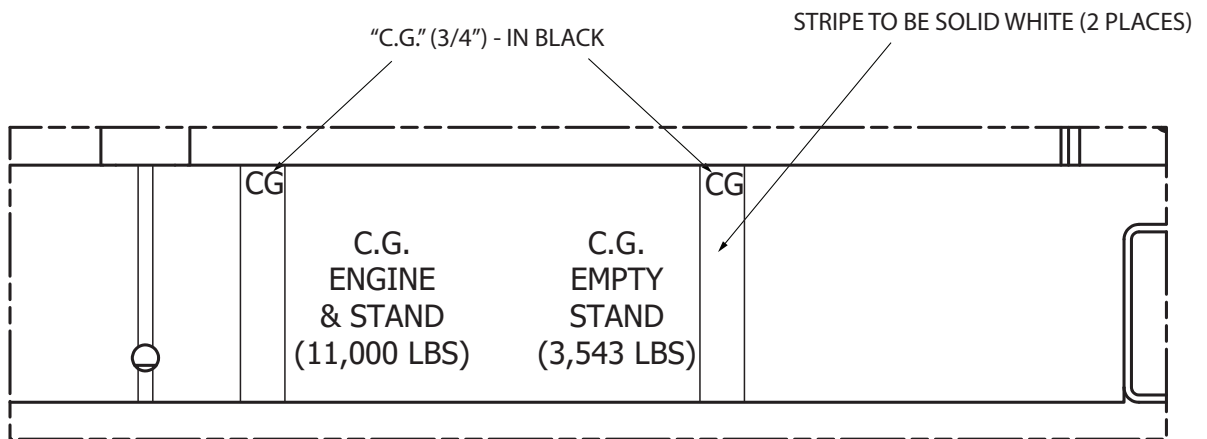

Figure 9.2-1



"TOW BAR STOW" (3/4")

**VIEW A**



**DETAIL "A"**

*Figure 9.2-2*

---

---

# 10.0 – Recommended Spares

---

---

## 10.1 Critical Items

AGSE defines “critical” items as those items, if broken or missing, that would render the equipment inoperable or severely impair equipment operation. Since most of these items are also long leads, it is AGSE’s recommendation that such items be identified, purchased, and stocked by the customer. In the remote event of “critical” item failure, the equipment can be quickly repaired and placed back in service with minimal down time.

AGSE does not typically stock all components used with the equipment, so immediate shipment of “critical” items may not always be possible. AGSE will respond to customer requests for quotation on any spare parts, and expedite orders for spare parts as required. The customer should never assume immediate delivery is always possible.

It is the responsibility of the operator of the equipment to review the recommended spares list and balance costs against equipment down-time. The list can be adjusted by the operator based on the actual service life of components experienced during equipment usage.

<b>PART NUMBER</b>	<b>QTY</b>	<b>PART DESCRIPTION</b>
AGSE-S00304-P04	8	Shock Mount
AM-90375-48T	4	Safety Pin
AM-90750-64T	6	Safety Pin
AGSE-E26225-P01	2	Pivot Pin
AM-91000-34T	2	Safety Pin
AGSE-E26214-P01	2	Safety Pin
AM-91000-64T	2	Safety Pin
AGSE-E25902-P01	3	Safety Pin
AM-90500-128L	2	Safety Pin
AM-90500-128T	2	Safety Pin
90293A414	2	Ball Lock Pin
AGSE-E25939-P01	2	Pivot Pin - 1”
AGSE-E25953-P01	1	GPS Bumper
AGSE-E25954-P01	1	GPS Bracket Weldment